

Robert Bosch Power Tools GmbH
70538 Stuttgart
GERMANY

www.bosch-pt.com

1 609 92A 52B (2019.06) T / 46



1 609 92A 52B

GST 25 M Professional

 **BOSCH**

en Original instructions
zh 正本使用说明书
zh 原始使用說明書
ko 사용 설명서 원본
th หนังสือคู่มือการใช้งานฉบับ ต้นแบบ
id Petunjuk-Petunjuk untuk Penggunaan Orisinal
vi Bản gốc hướng dẫn sử dụng

English	Page	5
中文	页	11
繁體中文	頁	16
한국어	페이지	20
ไทย	หน้า	25
Bahasa Indonesia	Halaman	30
Tiếng Việt	Trang	35

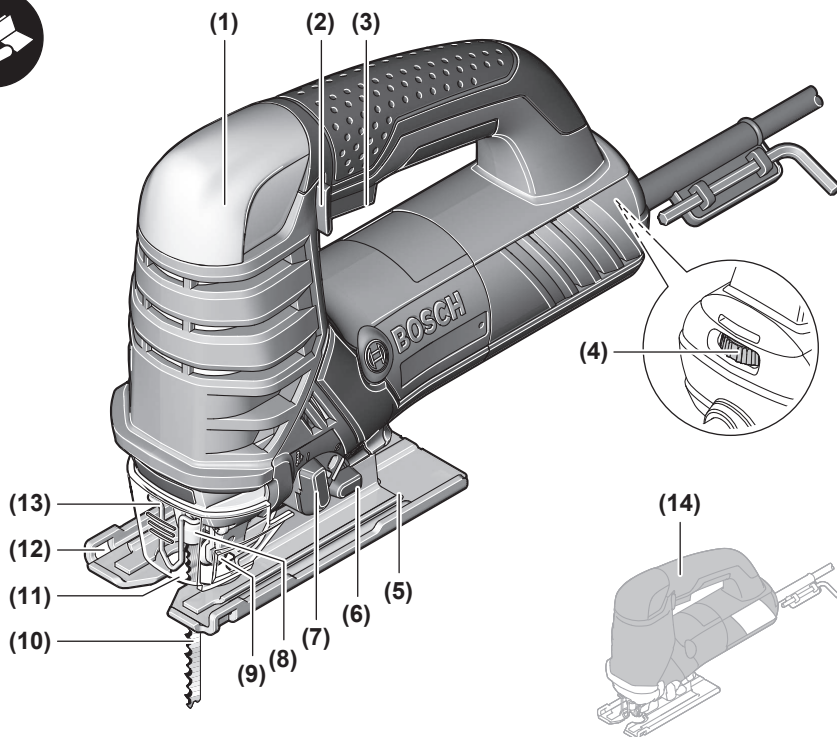

GST 25 M

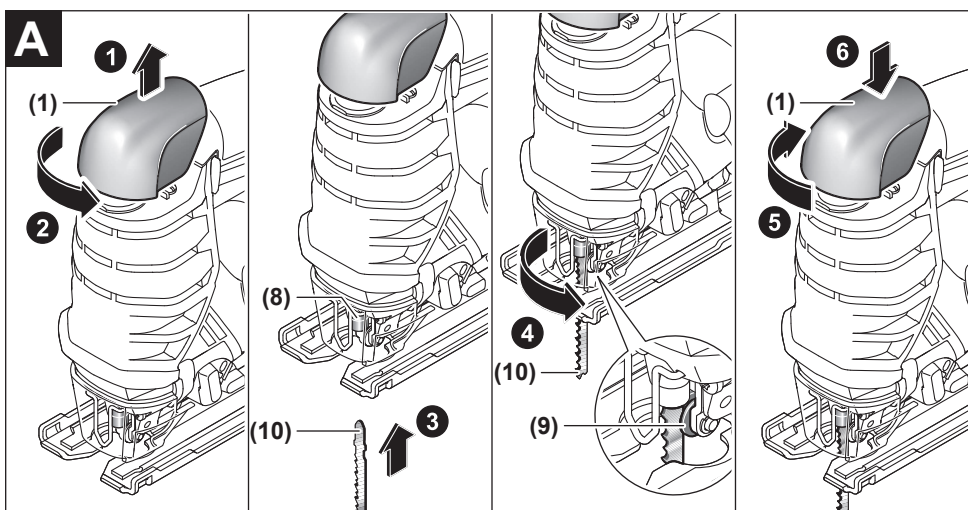

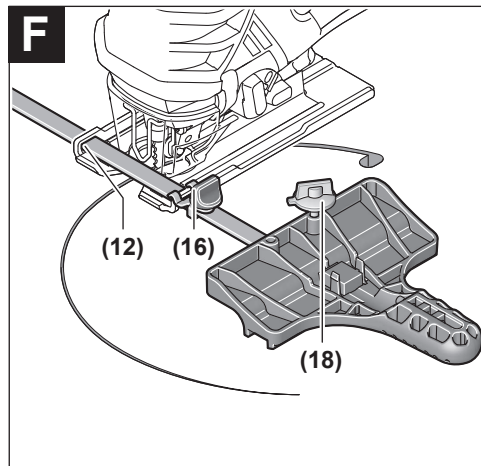
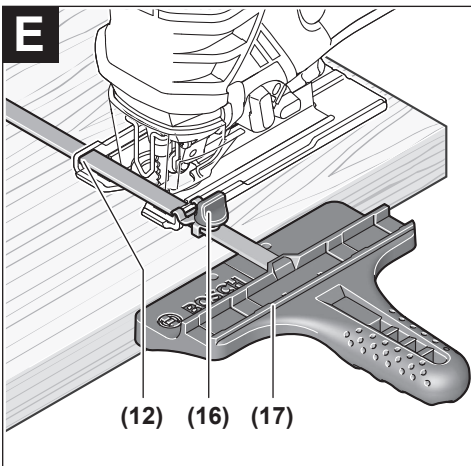
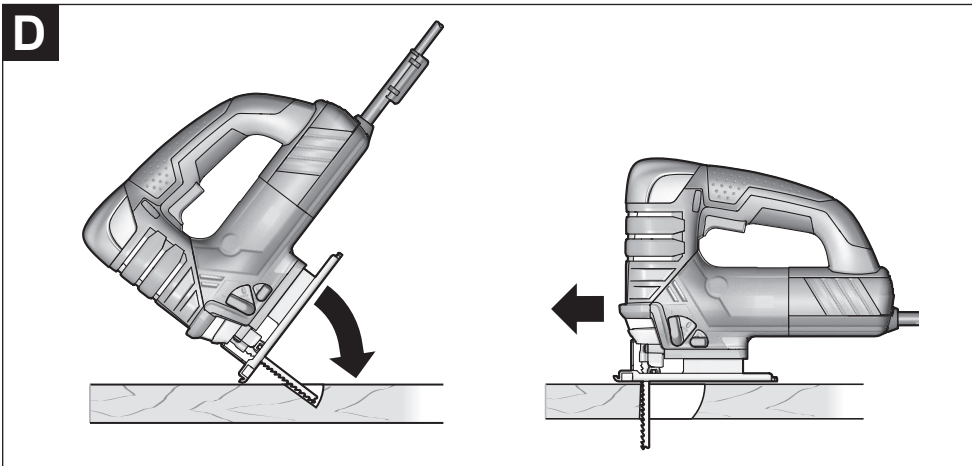
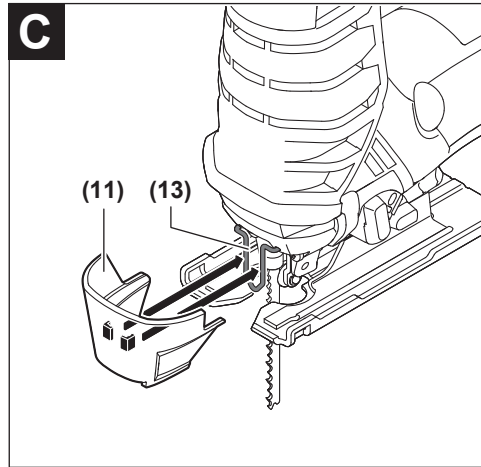
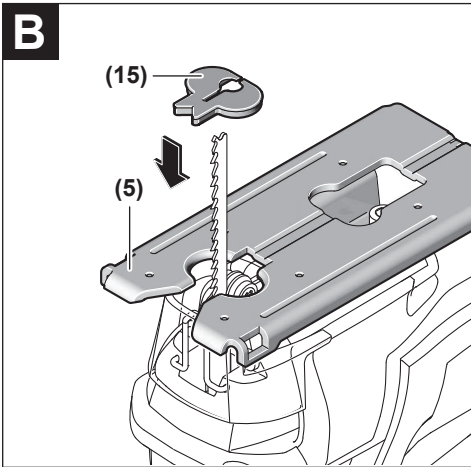

English

Safety instructions

General Power Tool Safety Warnings

⚠ WARNING Read all safety warnings, instructions, illustrations and specifications provided with this power tool. Failure to follow all instructions listed below may result in electric shock, fire and/or serious injury.

Save all warnings and instructions for future reference.

The term "power tool" in the warnings refers to your mains-operated (corded) power tool or battery-operated (cordless) power tool.

Work area safety

- ▶ **Keep work area clean and well lit.** Cluttered or dark areas invite accidents.
- ▶ **Do not operate power tools in explosive atmospheres, such as in the presence of flammable liquids, gases or dust.** Power tools create sparks which may ignite the dust or fumes.
- ▶ **Keep children and bystanders away while operating a power tool.** Distractions can cause you to lose control.

Electrical safety

- ▶ **Power tool plugs must match the outlet. Never modify the plug in any way. Do not use any adapter plugs with earthed (grounded) power tools.** Unmodified plugs and matching outlets will reduce risk of electric shock.
- ▶ **Avoid body contact with earthed or grounded surfaces, such as pipes, radiators, ranges and refrigerators.** There is an increased risk of electric shock if your body is earthed or grounded.
- ▶ **Do not expose power tools to rain or wet conditions.** Water entering a power tool will increase the risk of electric shock.
- ▶ **Do not abuse the cord. Never use the cord for carrying, pulling or unplugging the power tool. Keep cord away from heat, oil, sharp edges or moving parts.** Damaged or entangled cords increase the risk of electric shock.
- ▶ **When operating a power tool outdoors, use an extension cord suitable for outdoor use.** Use of a cord suitable for outdoor use reduces the risk of electric shock.
- ▶ **If operating a power tool in a damp location is unavoidable, use a residual current device (RCD) protected supply.** Use of an RCD reduces the risk of electric shock.

Personal safety

- ▶ **Stay alert, watch what you are doing and use common sense when operating a power tool. Do not use a power tool while you are tired or under the influence of drugs, alcohol or medication.** A moment of inatten-

tion while operating power tools may result in serious personal injury.

- ▶ **Use personal protective equipment. Always wear eye protection.** Protective equipment such as a dust mask, non-skid safety shoes, hard hat or hearing protection used for appropriate conditions will reduce personal injuries.
- ▶ **Prevent unintentional starting. Ensure the switch is in the off-position before connecting to power source and/or battery pack, picking up or carrying the tool.** Carrying power tools with your finger on the switch or energising power tools that have the switch on invites accidents.
- ▶ **Remove any adjusting key or wrench before turning the power tool on.** A wrench or a key left attached to a rotating part of the power tool may result in personal injury.
- ▶ **Do not overreach. Keep proper footing and balance at all times.** This enables better control of the power tool in unexpected situations.
- ▶ **Dress properly. Do not wear loose clothing or jewellery. Keep your hair and clothing away from moving parts.** Loose clothes, jewellery or long hair can be caught in moving parts.
- ▶ **If devices are provided for the connection of dust extraction and collection facilities, ensure these are connected and properly used.** Use of dust collection can reduce dust-related hazards.
- ▶ **Do not let familiarity gained from frequent use of tools allow you to become complacent and ignore tool safety principles.** A careless action can cause severe injury within a fraction of a second.

Power tool use and care

- ▶ **Do not force the power tool. Use the correct power tool for your application.** The correct power tool will do the job better and safer at the rate for which it was designed.
- ▶ **Do not use the power tool if the switch does not turn it on and off.** Any power tool that cannot be controlled with the switch is dangerous and must be repaired.
- ▶ **Disconnect the plug from the power source and/or remove the battery pack, if detachable, from the power tool before making any adjustments, changing accessories, or storing power tools.** Such preventive safety measures reduce the risk of starting the power tool accidentally.
- ▶ **Store idle power tools out of the reach of children and do not allow persons unfamiliar with the power tool or these instructions to operate the power tool.** Power tools are dangerous in the hands of untrained users.
- ▶ **Maintain power tools and accessories. Check for misalignment or binding of moving parts, breakage of parts and any other condition that may affect the power tool's operation. If damaged, have the power tool repaired before use.** Many accidents are caused by poorly maintained power tools.

- ▶ **Keep cutting tools sharp and clean.** Properly maintained cutting tools with sharp cutting edges are less likely to bind and are easier to control.
- ▶ **Use the power tool, accessories and tool bits etc. in accordance with these instructions, taking into account the working conditions and the work to be performed.** Use of the power tool for operations different from those intended could result in a hazardous situation.
- ▶ **Keep handles and grasping surfaces dry, clean and free from oil and grease.** Slippery handles and grasping surfaces do not allow for safe handling and control of the tool in unexpected situations.

Service

- ▶ **Have your power tool serviced by a qualified repair person using only identical replacement parts.** This will ensure that the safety of the power tool is maintained.

Safety instructions for jigsaws

- ▶ **Hold the power tool by insulated gripping surfaces, when performing an operation where the cutting accessory may contact hidden wiring or its own cord.** Cutting accessory contacting a "live" wire may make exposed metal parts of the power tool "live" and could give the operator an electric shock.
- ▶ **Use clamps or another practical way to secure and support the workpiece to a stable platform.** Holding the workpiece by hand or against your body leaves it unstable and may lead to loss of control.
- ▶ **Keep hands away from the sawing area. Do not reach under the workpiece.** Contact with the saw blade can lead to injuries.
- ▶ **Only bring the power tool into contact with the workpiece when switched on.** Otherwise there is danger of kickback if the cutting tool jams in the workpiece.
- ▶ **Ensure that the footplate always rests securely while sawing.** A jammed saw blade can break or lead to kickback.
- ▶ **When the cut is completed, switch off the power tool and then pull the saw blade out of the cut only after it has come to a standstill.** In this manner you can avoid kickback and can place down the power tool securely.
- ▶ **Always wait until the power tool has come to a complete stop before placing it down.** The application tool can jam and cause you to lose control of the power tool.
- ▶ **Use only undamaged saw blades that are in perfect condition.** Bent or dull saw blades can break, negatively influence the cut, or lead to kickback.
- ▶ **Do not brake the saw blade to a stop by applying side pressure after switching off.** The saw blade can be damaged, break or cause kickback.
- ▶ **Use suitable detectors to determine if utility lines are hidden in the work area or call the local utility company for assistance.** Contact with electric lines can lead to fire and electric shock. Damaging a gas line can lead to explosion. Penetrating a water line causes property damage or may cause an electric shock.

Products sold in GB only:

Your product is fitted with an BS 1363/A approved electric plug with internal fuse (ASTA approved to BS 1362).

If the plug is not suitable for your socket outlets, it should be cut off and an appropriate plug fitted in its place by an authorised customer service agent. The replacement plug should have the same fuse rating as the original plug.

The severed plug must be disposed of to avoid a possible shock hazard and should never be inserted into a mains socket elsewhere.

Product Description and Specifications



Read all the safety and general instructions.

Failure to observe the safety and general instructions may result in electric shock, fire and/or serious injury.

Please observe the illustrations at the beginning of this operating manual.

Intended Use

The power tool is intended for making separating cuts and cut-outs in wood, plastic, metal, ceramic plates and rubber while resting firmly on the workpiece. It is suitable for straight and curved cuts. The saw blade recommendations are to be observed.

Product Features

The numbering of the product features refers to the diagram of the power tool on the graphics page.

- (1) SDS twist cap for saw blade release
- (2) On/off switch locking mechanism
- (3) On/off switch
- (4) Stroke rate preselection thumbwheel
- (5) Base plate
- (6) Sawdust blower device switch
- (7) Orbital action adjusting lever
- (8) Saw blade receptacle
- (9) Guide roller
- (10) Saw blade^{A)}
- (11) Hood
- (12) Guide for parallel guide
- (13) Shock protection guard
- (14) Handle (insulated gripping surface)
- (15) Anti-splinter guard^{A)}
- (16) Locking screw for parallel guide^{A)}
- (17) Parallel guide with circle cutter^{A)}
- (18) Circle cutter centring tip^{A)}

A) **Accessories shown or described are not included with the product as standard. You can find the complete selection of accessories in our accessories range.**

Technical Data

Jigsaw		GST 25 M	
Article number		3 601 E16 ...	
Stroke rate control		●	
Constant electronic control		●	
Rated power input	W	670	
No-load stroke rate n_0	min ⁻¹	500–2600	
Stroke	mm	24	
Max. cutting depth			
– In wood	mm	80	
– In aluminium	mm	25	
– In steel (unalloyed)	mm	15	
Weight according to EPTA-Procedure 01:2014	kg	2.7	
Protection class		□/II	

The specifications apply to a rated voltage [U] of 230 V. These specifications may vary at different voltages and in country-specific models.

Assembly

- ▶ **Pull the plug out of the socket before carrying out any work on the power tool.**

Inserting/changing the saw blade

- ▶ **When fitting or changing the saw blade, wear protective gloves.** Blades are sharp and can become hot when used for prolonged periods of time.

Selecting the saw blade

You will find an overview of recommended saw blades at the end of these operating instructions. Only use saw blades with single lug shank (T shank). The saw blade should not be longer than required for the intended cut.

Use a narrow saw blade when sawing tight curves.

Inserting/removing the saw blade (see figure A)

- ▶ **Clean the shaft on the saw blade before inserting it.**

A dirty shaft cannot be securely fixed in place.

- 1 Pull the SDS twist cap (1) up.
- 2 To unlock, turn the SDS twist cap (1) approximately 3 turns anticlockwise.
- 3 Insert the saw blade (10) into the saw blade receptacle (8) perpendicular to the cutting direction.
- 4 Turn the saw blade (10) so that the teeth point in the cutting direction. Make sure that the back of the saw blade is in the groove on the guide roller (9).
- 5 Turn the SDS twist cap (1) clockwise until it clicks.
- 6 Turn the SDS twist cap (1) further clockwise until it reaches its initial position. Slide the SDS twist cap down to lock it in place.

- ▶ **Check that the saw blade is seated securely.** A loose saw blade can fall out and lead to injuries.

To remove the saw blade, follow the steps above in reverse.

Anti-splinter guard (see figure B)

The anti-splinter guard (15) (accessory) can prevent splintering of the surface while sawing wood. The anti-splinter guard can only be used with certain saw blade types.

Push the anti-splinter guard (15) into the base plate (5) from below.

Dust/Chip Extraction

Dust from materials such as lead-containing coatings, some wood types, minerals and metal can be harmful to one's health. Touching or breathing-in the dust can cause allergic reactions and/or lead to respiratory infections of the user or bystanders.

Certain dust, such as oak or beech dust, is considered carcinogenic, especially in connection with wood-treatment additives (chromate, wood preservative). Materials containing asbestos may only be worked by specialists.

- Provide for good ventilation of the working place.
- It is recommended to wear a P2 filter-class respirator.

Observe the relevant regulations in your country for the materials to be worked.

- ▶ **Avoid dust accumulation at the workplace.** Dust can easily ignite.

Hood (see figure C)

Danger of injury from sharp-edged and hot metal chips/shavings. When working with metal or aluminium, you must therefore attach the hood (11).

Attach the hood (11) to the power tool so that the bracket locks into place on the shock protection guard (13).

Remove the hood (11) to work with wood. To do this, pull the hood forwards off the shock protection guard (13).

Operation

- ▶ **Products that are only sold in AUS and NZ:** Use a residual current device (RCD) with a nominal residual current of 30 mA or less.

Operating modes

- ▶ **Pull the plug out of the socket before carrying out any work on the power tool.**

Orbital action

The orbital action allows for optimal adaptation of cutting speed, cutting capacity and cutting pattern to the material being machined.

Switch on the orbital action, e.g. for sawing soft materials and for sawing wood in the direction of the grain. Do this by sliding the adjusting lever (7) to the "I" position. This can also be done during operation.

Switch off the orbital action for fine and clean cut edges when machining thin materials (e.g. sheets). Do this by sliding the adjusting lever (7) to the "0" position.

Sawdust blower device

The cutting line can be kept clear of chips using the airflow from the sawdust blower device.

Switch on the sawdust blower device for work in wood, plastic, etc. with a high level of material removal. Do this by sliding the switch (6) to the "I" position.

Switch off the sawdust blower device when working in metal. Do this by sliding the switch (6) to the "0" position.

Starting Operation

- ▶ **Pay attention to the mains voltage. The voltage of the power source must match the voltage specified on the rating plate of the power tool. Power tools marked with 230 V can also be operated with 220 V.**

Switching on/off

- ▶ **Make sure that you are able to press the On/Off switch without releasing the handle.**

To **switch on** the power tool, press the on/off switch (3).

To **lock** the on/off switch (3), keep it pressed down and push the locking mechanism (2) to the right or left.

To **switch off** the power tool, release the on/off switch (3). If the on/off switch (3) is locked, press the switch first and then release it.

Constant Electronic control

The Constant Electronic control keeps the stroke rate at no load and under load virtually consistent, guaranteeing uniform performance.

Controlling/preselecting the stroke rate

You can variably adjust the stroke rate of the power tool when it is on by pressing in the on/off switch (3) to varying extents.

Applying light pressure to the on/off switch (3) results in a low stroke rate. Applying increasing pressure to the switch increases the stroke rate.

It is not possible to reduce the stroke rate while the on/off switch (3) is locked.

You can also preselect the stroke rate and change it during operation using the stroke rate preselection thumbwheel (4).

The required stroke rate is dependent on the material and the work conditions and can be determined using practical tests.

It is recommended that you reduce the stroke rate when placing the saw blade on the workpiece and when sawing plastic and aluminium.

During prolonged periods of use at a low stroke rate, the power tool may heat up significantly. Remove the saw blade and let the power tool run at the maximum stroke rate for around three minutes to cool down.

Working Advice

- ▶ **Pull the plug out of the socket before carrying out any work on the power tool.**

- ▶ **Switch the power tool off immediately if the saw blade becomes blocked.**

- ▶ **Always use a sturdy support when working on small or thin workpieces.**

Before sawing into wood, chipboard, building materials, etc., check for and remove any foreign objects such as nails, screws, etc.

Plunge cutting (see figure D)

- ▶ **Plunge cuts may only be applied to soft materials, such as softwood, gypsum board, etc.**

For plunge cutting, use only short saw blades.

Place the power tool so that the front edge of the base plate (5) rests on the workpiece, without the saw blade (10) touching the workpiece, and switch it on. On power tools with stroke rate control, select the maximum stroke rate.

Press the power tool firmly against the workpiece and allow the saw blade to plunge slowly into the workpiece.

As soon as the base plate (5) rests fully on the workpiece, continue sawing along the required cutting line.

Parallel guide with circle cutter (accessory)

When working with the parallel guide with circle cutter (17) (accessory), the workpiece must be no more than 30 mm thick.

Parallel cuts (see figure E): Loosen the locking screw (16) and slide the scale on the parallel guide through the guide (12) in the base plate. Adjust the desired cutting width as a scale value on the inside edge of the base plate. Retighten the locking screw (16).

Circular cuts (see figure F): Drill a hole large enough to push the saw blade through on the cutting line within the circle to be cut. Machine the drill hole with a router or file so that the saw blade can lie flush with the cutting line.

Position the locking screw (16) on the other side of the parallel guide. Slide the scale on the parallel guide through the guide (12) into the base plate. Drill a hole in the workpiece in the middle of the section to be cut out. Insert the centring tip (18) through the inner opening of the parallel guide and into the drilled hole. Adjust the radius as a scale value on the inside edge of the base plate. Retighten the locking screw (16).

Coolant/lubricant

As the material heats up along the cutting line when cutting metal, you should apply coolant or lubricant.

Maintenance and Service

Maintenance and Cleaning

- ▶ **Pull the plug out of the socket before carrying out any work on the power tool.**
- ▶ **To ensure safe and efficient operation, always keep the power tool and the ventilation slots clean.**

In order to avoid safety hazards, if the power supply cord needs to be replaced, this must be done by **Bosch** or by an

after-sales service centre that is authorised to repair **Bosch** power tools.

Clean the saw blade receptacle regularly. For this, remove the saw blade from the power tool and lightly tap out the power tool on a level surface.

If the power tool becomes very dirty, this can lead to serious faults. For this reason, do not cut materials which generate large quantities of dust from below or overhead.

► **In extreme conditions, always use a dust extractor if possible. Blow out ventilation slots frequently and install a residual current device (RCD) upstream.** When machining metals, conductive dust can settle inside the power tool, which can affect its protective insulation.

Apply a drop of oil to the guide roller **(9)** from time to time.

Check the guide roller **(9)** regularly. If worn, it must be replaced through an authorised **Bosch** after-sales service centre.

After-Sales Service and Application Service

Our after-sales service responds to your questions concerning maintenance and repair of your product as well as spare parts. You can find explosion drawings and information on spare parts at: **www.bosch-pt.com**

The Bosch product use advice team will be happy to help you with any questions about our products and their accessories.

In all correspondence and spare parts orders, please always include the 10-digit article number given on the nameplate of the product.

Cambodia

Robert Bosch (Cambodia) Co., Ltd
Unit 8BC, GT Tower, 08th Floor, Street 169,
Czechoslovakia Blvd, Sangkat Veal Vong
Khan 7 Makara, Phnom Penh
VAT TIN: 100 169 511
Tel.: +855 23 900 685
Tel.: +855 23 900 660
www.bosch.com.kh

People's Republic of China

China Mainland

Bosch Power Tool (China) Co. Ltd.
Bosch Service Center
567, Bin Kang Road
Bin Kang District
Hangzhou, Zhejiang Province
China 310052
Tel.: (0571) 8887 5566 / 5588
Fax: (0571) 8887 6688 x 5566# / 5588#
E-Mail: bsc.hz@cn.bosch.com
www.bosch-pt.com.cn

HK and Macau Special Administrative Regions

Robert Bosch Co. Ltd.
Flat B, 2/F, Yeung Yiu Chung No. 6 Industrial Building,
19 Cheung Shun Street
Cheung Sha Wan
Kowloon, Hong Kong
Customer Service Hotline: +852 2101 0235

Fax: +852 2590 9762
E-Mail: info@hk.bosch.com
www.bosch-pt.com.hk

India

Bosch Service Center
69, Habibullah Road, (next to PSBB School), T. Nagar
Chennai-600077
Phone: (044) 64561816

Bosch Service Center Rishyamook
85A, Panchkuin Road
New Delhi-110001
Phone: (011) 43166190

Bosch Service Center 79,
Crystal Bldg., Dr. Annie Besant Road, Worli
Mumbai-400018
Phone: (022) 39569936 / (022) 39569959 /
(022) 39569967 / (022) 24952071

Indonesia

PT Robert Bosch
Palma Tower 10th Floor
Jalan RA Kartini II-S Kaveling 6
Pondok Pinang, Kebayoran Lama
Jakarta Selatan 12310
Tel.: (21) 3005-5800
www.bosch-pt.co.id

Malaysia

Robert Bosch Sdn. Bhd.(220975-V) PT/SMY
No. 8A, Jalan 13/6
46200 Petaling Jaya
Selangor
Tel.: (03) 79663194
Toll-Free: 1800 880188
Fax: (03) 79583838
E-Mail: kiathoe.chong@my.bosch.com
www.bosch-pt.com.my

Pakistan

Robert Bosch Middle East FZE – Pakistan Liaison Office
2nd Floor Plaza # 10, CCA Block, DHA Phase 5
Lahore, 54810
Phone: +92(303)4444311
Email: Faisal.Khan@bosch.com

Philippines

Robert Bosch, Inc.
28th Floor Fort Legend Towers,
3rd Avenue corner 31st Street,
Fort Bonifacio, Global City,
1634 Taguig City
Tel.: (632) 8703871
Fax: (632) 8703870
www.bosch-pt.com.ph

Singapore

Powerwell Service Centre Ptd Ltd
Bosch Authorised Service Centre (Power Tools)
4012 Ang Mo Kio Ave 10, #01-02 TECHplace
Singapore 569628
Tel.: 6452 1770

Fax: 6452 1760
 E-Mail: ask@powerwellsc.com
 www.powerwellsc.com
 www.bosch-pt.com.sg

Thailand

Robert Bosch Ltd.
 FYI Center Tower 1, 5th Floor,
 2525 Rama IV Road, Klongtoei,
 Bangkok 10110
 Tel.: 02 0128888
 Fax: 02 0645802
 www.bosch.co.th
 Bosch Service – Training Centre
 La Salle Tower Ground Floor Unit No.2
 10/11 La Salle Moo 16
 Srinakharin Road
 Bangkaew, Bang Plee
 Samutprakarn 10540
 Tel.: 02 7587555
 Fax: 02 7587525

Vietnam

Branch of Bosch Vietnam Co., Ltd in HCMC
 14th floor, Deutsches Haus, 33 Le Duan
 Ben Nghe Ward, District 1, Ho Chi Minh City
 Tel.: (028) 6258 3690
 Fax: (028) 6258 3692 - 6258 3694
 Hotline: (028) 6250 8555
 Email: tuvankhachhang-pt@vn.bosch.com
 www.bosch-pt.com.vn

Kyrgyzstan, Mongolia, Tajikistan, Turkmenistan, Uzbekistan

TOO "Robert Bosch" Power Tools, After Sales Service
 Muratbaev Ave., 180
 050012, Almaty, Kazakhstan
 Service Email: service.pt.ka@bosch.com
 Official Website: www.bosch.com, www.bosch-pt.com

Armenia, Azerbaijan, Georgia

Robert Bosch Ltd.
 David Agmashenebeli ave. 61
 0102 Tbilisi, Georgia
 Tel. +995322510073
 www.bosch.com

Bahrain

EA Juffali and Brothers for Technical Equipment Company.
 Kingdom of Bahrain, Al Aker - Block 0624 - Road 2403 -
 Building 0055D
 Phone: +97317704537
 Fax: +973177045257
 Email: h.berjas@ejb.com.sa

Egypt

RBEG-LLC
 22 Kamal Eldin Hussein
 Sheraton Heliopolis
 11799 Cairo
 E-mail: boschegypt.powertools@eg.bosch.com

Iran

Robert Bosch Iran
 3rd Floor, No 3, Maadiran Building
 Aftab St., Khodami St., Vanak Sq.
 Tehran 1994834571
 Phone: +9821- 86092057

Iraq

Sahba Technology Group
 Al Muthana airport road
 Baghdad
 Phone Bagdad: +964 (0) 7 901 930366
 Phone Dubai: +971 (0) 4 422 1898
 Email: duraid@sahbatechnology.com

Jordan

Roots Arabia – Jordan
 Al-Hurriyah Street, Al-Muqabalein
 Amman 11623, Jordan
 P.O. Box: 110068
 Tel. : +962 6 4398990
 E-mail: bosch@rootsjordan.com

Kuwait

Shuwaikh Industrial Area, Block 1, Plot 16, Street 3rd
 P.O. Box 164 – Safat 13002
 Phone: +965 - 2496 88 88
 Fax: +965 - 2481 08 79
 E-mail: josephkr@aaalmutawa.com

Lebanon

Tehini Hana & Co. S.A.R.L.
 P.O. Box 90-449
 Jdeideh 1202 2040
 Dora-Beirut
 Phone: +9611255211
 Email: service-pt@tehini-hana.com

Libya

El Naser for Workshop Tools
 Swanee Road, Alfalah Area
 Tripoli
 Phone: +218 21 4811184

Oman

Malatan Trading & Contracting LLC
 P.O. Box 131, Ruwi, Muscat
 Postal Code: 112, Sultanate of Oman
 Phone: +968 2479 4035/4089/4901
 Mob: +968-91315465
 Fax: +968 2479 4058
 E-Mail: sudhirkumar@malatan.net

Qatar

International Construction Solutions W L L
 P. O. Box 51, Doha
 Phone: +974 40065458
 Fax: +974 4453 8585
 Email: csd@icsdoha.com

Saudi Arabia

Juffali Technical Equipment Co. (JTECO)
 P.O.Box: 1049 – Jeddah 21431 – KSA
 Jeddah: 00966 (0) 12 692 0770 – Ext 433

Riyadh: 00966 (0) 11 409 3976 – Ext-30/34/39
 Dammam: 00966 (0) 13 833 9565
 E-mail: M.Zreik@eajb.com.sa

Syria

Dallal Establishment for Power Tools
 Damascus. Baramkeh street - Ibn Amer street,
 Phone: +963112241006 or 009631122414009
 Mobile: 00963991141005
 Email: rita.dallal@hotmail.com

United Arab Emirates

Central Motors & Equipment,
 P.O. Box 26255, Dubai
 Dubai: 00971 (0) 4 3090920/3090930
 Abu Dhabi: 00971 (0) 2 4017745
 Sharjah: 00971 (0) 6 5932777
 Al Ain: 00971 (0) 3 7157419
 E-Mail: Mallappa.Madari@centralmotors.ae

Yemen

Abu Alrejal Trading Corporation
 P.O. Box : 17024 , Zubeiry St.
 Sana'a, Yemen
 Tel: +967-1-20 20 10
 Fax: +967-1-47 19 17
 E-mail: tech-tools@abualrejal.com/yahya@abualrejal.com

Ethiopia

Forever plc
 Kebele 2,754, BP 4806,
 Addis Ababa
 Phone: +251 111 560 600
 Email: foreverplc@ethionet.et

Ghana

Robert Bosch Ghana Limited
 21 Kofi Annan Road Airport Residential Area Accra
 Tel. +233 (0)3027 94616

Kenya

Robert Bosch East Africa Ltd
 Mpaka Road P.O. Box 856
 00606 Nairobi

Nigeria

Robert Bosch Nigeria Ltd.
 52-54 Isaac John Street P.O. Box
 GRA Ikeja – Lagos

Republic of South Africa

Customer service

Hotline: (011) 6519600

Gauteng – BSC Service Centre

35 Roper Street, New Centre
 Johannesburg
 Tel.: (011) 4939375
 Fax: (011) 4930126
 E-Mail: bsctools@icon.co.za

KZN – BSC Service Centre

Unit E, Almar Centre
 143 Crompton Street
 Pinetown

Tel.: (031) 7012120
 Fax: (031) 7012446
 E-Mail: bsc.dur@za.bosch.com

Western Cape – BSC Service Centre

Democracy Way, Prosperity Park
 Milnerton
 Tel.: (021) 5512577
 Fax: (021) 5513223
 E-Mail: bsc@zsd.co.za

Bosch Headquarters

Midrand, Gauteng
 Tel.: (011) 6519600
 Fax: (011) 6519880
 E-Mail: rbsa-hq.pts@za.bosch.com

Tanzania

Diesel & Autoelectric Service Ltd.
 117 Nyerere Rd., P.O. Box 70839
 Vingunguti 12109, Dar Es Salaam
 Phone: +255 222 861 793/794

Australia, New Zealand and Pacific Islands

Robert Bosch Australia Pty. Ltd.

Power Tools
 Locked Bag 66
 Clayton South VIC 3169
 Customer Contact Center
 Inside Australia:
 Phone: (01300) 307044
 Fax: (01300) 307045
 Inside New Zealand:
 Phone: (0800) 543353
 Fax: (0800) 428570
 Outside AU and NZ:
 Phone: +61 3 95415555
 www.bosch-pt.com.au
 www.bosch-pt.co.nz

Disposal

The power tool, accessories and packaging should be recycled in an environmentally friendly manner.



Do not dispose of power tools along with household waste.

中文

安全规章

电动工具通用安全警告

警告！阅读所有警告和所有说明！

不遵照以下警告和说明会导致电击、着火和 / 或严重伤害。

保存所有警告和说明书以备查阅。

在所有下列的警告中术语“电动工具”指市电驱动（有线）电动工具或电池驱动（无线）电动工具。

工作场地的安全

- ▶ **保持工作场地清洁和明亮。** 混乱和黑暗的场地会引发事故。
- ▶ **不要在易爆环境，如有易燃液体、气体或粉尘的环境下操作电动工具。** 电动工具产生的火花会点燃粉尘或气体。
- ▶ **让儿童和旁观者离开后操作电动工具。** 注意力不集中会使操作者失去对工具的控制。

电气安全

- ▶ **电动工具插头必须与插座相配。绝不能以任何方式改装插头。** 需接地的电动工具不能使用任何转换插头。未经改装的插头和相配的插座将减少电击危险。
- ▶ **避免人体接触接地表面，如管道、散热片和冰箱。** 如果你身体接地会增加电击危险。
- ▶ **不得将电动工具暴露在雨中或潮湿环境中。** 水进入电动工具将增加电击危险。
- ▶ **不得滥用电缆。** 绝不能用电线搬运、拉动电动工具或拔出其插头。使电线远离热源、油、锐边或运动部件。受损或缠绕的软线会增加电击危险。
- ▶ **当在户外使用电动工具时，使用适合户外使用的外接软线。** 适合户外使用的软线将减少电击危险。
- ▶ **如果在潮湿环境下操作电动工具是不可避免的，应使用剩余电流动作保护器（RCD）。** 使用RCD可减小电击危险。

人身安全

- ▶ **保持警觉，当操作电动工具时关注所从事的操作并保持清醒。** 当你感到疲倦，或在有药物、酒精或治疗反应时，不要操作电动工具。在操作电动工具时瞬间的疏忽会导致严重人身伤害。
- ▶ **使用个人防护装置。始终佩戴护目镜。** 安全装置，诸如适当条件下使用防尘面具、防滑安全鞋、安全帽、听力防护等装置能减少人身伤害。
- ▶ **防止意外起动。确保开关在连接电源和/或电池盒、拿起或搬运工具时处于关断位置。** 手指放在已接通电源的开关上或开关处于接通时插入插头可能会导致危险。
- ▶ **在电动工具接通之前，拿掉所有调节钥匙或扳手。** 遗留在电动工具旋转零件上的扳手或钥匙会导致人身伤害。

- ▶ **手不要伸展得太长。时刻注意立足点和身体平衡。** 这样在意外情况下能很好地控制电动工具。
- ▶ **着装适当。不要穿宽松衣服或佩戴饰品。** 让衣服、手套和头发远离运动部件。宽松衣服、配饰或长发可能会卷入运动部件中。
- ▶ **如果提供了与排屑、集尘设备连接用的装置，要确保他们连接完好且使用得当。** 使用这些装置可减少尘屑引起的危险。
- ▶ **即使由于经常使用电动工具而对此非常熟悉，也不要就认为可以高枕无忧而忽略工具的安全规定。** 粗心大意的行为可能在瞬间就造成严重的伤害。

电动工具使用和注意事项 电动工具使用和注意事项

- ▶ **不要滥用电动工具，根据用途使用适当的电动工具。** 选用适当设计的电动工具会使你工作更有效、更安全。
 - ▶ **如果开关不能接通或关断工具电源，则不能使用该电动工具。** 如果开关不能接通或关断工具电源，则不能使用该电动工具。
 - ▶ **在进行任何调节、更换附件或贮存电动工具之前，必须从电源上拔掉插头和/或使电池盒与工具脱开。** 这种防护性措施将减少工具意外起动的危险。
 - ▶ **将闲置不用的电动工具贮存在儿童所及范围之外，并且不要让不熟悉电动工具或对这些说明不了解的人操作电动工具。** 电动工具在未经培训的用户手中是危险的。
 - ▶ **保养电动工具。检查运动件是否调整到位或卡住，检查零件破损情况和影响电动工具运行的其他状况。** 如有损坏，电动工具应在使用前修理好。许多事故由维护不良的电动工具引发。
 - ▶ **保持切削刀具锋利和清洁。** 保养良好的有锋利切削刃的刀具不易卡住而且容易控制。
 - ▶ **按照使用说明书，考虑作业条件和进行的作业来使用电动工具、附件和工具的刀头等。** 将电动工具用于那些与其用途不符的操作可能会导致危险。
 - ▶ **保持手柄和握持表面干燥、清洁、无油污。** 在突发情况下，滑溜的手柄和握持表面无法确保安全地握持和控制工具。
- 维修**
- ▶ **将电动工具用于那些与其用途不符的操作可能会导致危险。** 这将确保所维修的电动工具的安全性。

针对线锯的安全规章

- ▶ 在切削附件可能触及暗线或其自身软线之处进行操作时，要通过绝缘握持面来握持工具。切削附件碰到带电导线会使工具外露的金属零件带电从而使操作者受到电击。
- ▶ 使用夹箍或其他实用方式将加工件固定和支撑到一个稳定的平台上。用手握住或用身体顶住加工件会导致不稳定，从而引起失控。
- ▶ 双手必须远离锯割范围，手不可以握在工件下端。如果不小心碰触了锯片可能被割伤。
- ▶ 先开动电动工具后再把工具放置在工件上切割。如果电动工具被夹在工件中，会有反弹的危险。
- ▶ 注意锯割时把底盘正确安稳地放置。锯片如果歪斜了，可能断裂或者造成反弹。
- ▶ 工作告一段落时，必须先关闭电动工具并等待机器完全静止后，才可以从锯缝中拔出锯刀。如此不但可以防止反弹，而且可以防止放置机器时发生危险。
- ▶ 等待电动工具完全静止后才能够放下机器。机器上的工具可能在工作中被夹住，而令您无法控制电动工具。
- ▶ 只能使用未受损的功能正常的锯片。弯曲或变钝的锯片可能断裂，对锯痕造成负面影响或导致反弹。
- ▶ 关机后不可以侧压刀片来制止仍然继续转动的刀片。锯刀可能因此受损、断裂或者造成反击。
- ▶ 使用合适的侦测装置侦察隐藏的电线，或者向当地的相关单位寻求支援。接触电线可能引起火灾并让操作者触电。损坏了瓦斯管会引起爆炸。凿穿水管不仅会造成严重的财物损失，也可能导致触电。

产品和性能说明



请阅读所有安全规章和指示。不遵照以下警告和说明可能导致电击、着火和/或严重伤害。

请注意本使用说明书开头部分的图示。

按照规定使用

本电动工具用于在稳固的底垫上对木材、塑料、金属、陶片和橡胶进行切割和开孔，适用于直线和曲线切割。请使用推荐的锯片。

插图上的机件

机件的编号和电动工具详解图上的编号一致。

- (1) 锯片解锁SDS旋转盖
- (2) 电源开关止动件

- (3) 电源开关
- (4) 冲击次数预选调节轮
- (5) 底板
- (6) 锯屑吹净装置开关
- (7) 振荡调整杆
- (8) 锯片架
- (9) 导引轮
- (10) 锯片^{A)}
- (11) 盖罩
- (12) 平行限制器的导引
- (13) 防割伤装置
- (14) 手柄（绝缘握柄）
- (15) 防毛边压板^{A)}
- (16) 平行限制器的固定螺丝^{A)}
- (17) 带开圆器的平行限制器^{A)}
- (18) 开圆器定心尖^{A)}

A) 图表或说明上提到的附件，并不包含在基本的供货范围中。本公司的附件清单中有完整的附件供应项目。

技术参数

曲线锯		GST 25 M
物品代码		3 601 E16 ...
冲击次数控制装置		●
恒定电子装置		●
额定输入功率	瓦	670
空载转速 n_0	转/分	500-2600
冲程	毫米	24
最大切割深度		
- 木材	毫米	80
- 铝材	毫米	25
- 钢材（非合金）	毫米	15
重量符合	公斤	2.7
EPTA-Procedure 01:2014		
保护等级		□/II

所有参数适用于230伏的额定电压[U]，对于其他不同的电压和国际规格，数据有可能不同。

安装

- ▶ 在电动工具上进行所有操作之前都必须从插座上拔出电源插头。

安装/更换锯片

- ▶ 安装或更换工具刀头时务必佩戴保护手套。工具刀头非常锋利，长时间使用后会变热。

选择锯片

在本说明书的最后有锯片的一览表。请只安装单凸轮轴（T型刀柄）的锯片。锯片长度不得超过预定锯线所需的数值。

在狭小的弯角上锯割时要使用窄的锯片。

装入/取出锯片（参见插图A）

► **安装前，请清洁锯片的柄部。**脏污的柄部无法牢固固定。

- ① 向上拉动SDS旋转盖(1)。
- ② 如要解锁，请逆时针转动SDS旋转盖(1)约3圈。
- ③ 将锯片(10)垂直于切割方向装入锯片架(8)。
- ④ 转动锯片(10)，使锯齿朝向切割方向。请注意锯片背位于导引轮(9)的槽内。
- ⑤ 顺时针转动SDS旋转盖(1)，直至其卡止。
- ⑥ 继续顺时针转动SDS旋转盖(1)，直至其回到初始位置。向下推动SDS旋转盖，将其锁止。

► **检查锯片是否牢固固定。**松脱的锯片会从接头掉落并伤害您。

拆卸锯刀时以相反的顺序进行。

防毛边压板（参见插图B）

防毛边压板(15)（附件）可以在锯割木材时防止表面裂开。防毛边压板只能用于特定的锯片类型。

将防毛边压板(15)从下方压入底板(5)。

吸尘罩/吸锯屑

含铅的颜料以及某些木材、矿物和金属的加工废尘有害健康。机器操作者或者工地附近的人如果接触、吸入这些废尘，可能会有过敏反应或者感染呼吸道疾病。

某些尘埃（例如加工橡木或山毛榉的废尘）可能致癌，特别是和处理木材的添加剂（例如木材的防腐剂等）结合之后。只有经过专业训练的人才能够加工含石棉的物料。

- 工作场所要保持空气流通。
- 最好佩戴P2滤网等级的口罩。

请留心并遵守贵国和加工物料有关的法规。

► **避免让工作场所堆积过多的尘垢。**尘埃容易被点燃。

盖罩（参见插图C）

边缘锋利或炙热的金属锯屑可能会造成伤害。因此在加工金属或铝材时请安装盖罩(11)。

将盖罩(11)放到电动工具上，以便支架卡入防割伤装置(13)。

加工木材时请取下盖罩(11)。为此，将盖罩向前从防割伤装置(13)上拉下。

操作

运行模式

► **在电动工具上进行所有操作之前都必须从插座上拔出电源插头。**

振荡功能

利用振荡功能可以根据加工物料适度配合锯割速度、锯割功率并产生最好的锯割效果。

例如锯割较软的材料或顺着木纹锯割木材时请开启振荡功能。为此，将调整杆(7)推到位置“1”。也可在操作中进行。

加工精细且干净的切边以及加工较薄的材料（例如板材）时请关闭振荡功能。为此，将调整杆(7)推到位置“0”。

锯屑吹净装置

利用锯屑吹净装置的气流可以清除切线上的锯屑。加工像木材、塑料等切屑去除量较大的材料时请接通锯屑吹净装置。为此，将开关(6)推到位置“1”。

加工金属时请关闭锯屑吹净装置。为此，将开关(6)推到位置“0”。

投入使用

► **注意电源电压！电源的电压必须和电动工具铭牌上标示的电压一致。标记为230伏电动工具用220伏的电压可以驱动。**

接通/关闭

► **请确保握住手柄时可以开启/关闭开关。**

要 **接通** 电动工具，按压起停开关(3)。

要 **锁定** 起停开关(3)，按住起停开关并向左或向右推动止动件(2)。

要**关闭**电动工具，松开起停开关(3)。起停开关(3)锁住时，请先按压，然后再松开。

恒定电子装置

有了恒定电子装置，机器的冲击次数能够在空转和负载时都保持恒定。如此能够确保均匀的运作功率。

控制/预选冲击次数

可以无级调节已接通电动工具的冲击次数，视按压起停开关(3)的力道程度决定。

以较小的力按压起停开关(3)时，冲击次数较低。逐渐在开关上加压，冲击次数也会跟着提高。

起停开关(3)锁定后，无法减少冲击次数。

利用冲击次数预选调节轮 (4) 也可以在运行过程中预选所需的冲击次数。

正确的冲击次数必须视工件物料和工作状况而定。

唯有实际操作才能找出最合适的冲击次数。

起锯时，或者锯割塑料、铝片时最好降低冲击次数。

以小的冲击次数长期工作之后，电动工具会变得很热。拆下锯片，让电动工具以最高冲击次数运作3分钟以加速冷却。

工作提示

▶ 在电动工具上进行所有操作之前都必须从插座上拔出电源插头。

▶ 当锯片被夹住时，请立即关闭电动工具。

▶ 加工小或薄的工件时，必须使用稳定的垫板。

锯切木材、刨花板、建筑材料等材料前应检查是否有异物，比如钉子、螺栓等类似物质，如果有的话，请清除。

潜锯 (见图片 D)

▶ 在切入式锯切工艺中，仅允许加工软材料，比如软木、石膏板等类似材料！

切入式锯切时只能使用短锯片。

将电动工具底板(5)的前边缘放到工件上，锯片(10)不要触碰到工件，然后接通。如果电动工具有冲击次数控制装置，必须选择最高冲击次数。将电动工具用力压向工件，并让锯片慢慢地切入工件中。

底板(5)齐平地贴着工件后，就可沿着所需的切线继续切割。

带开圆器的平行限制器 (附件)

使用带开圆器的平行限制器 (17) (附件) 进行加工时，工件厚度不得超过30 mm。

直线切割 (见图片 E)：松开固定螺丝 (16)，将平行限制器的刻度推过底板的导引 (12)。根据刻度尺调整好需要的锯割宽度。拧紧固定螺丝 (16)。

开圆 (见图片 F)：在待切割圆内的切线上钻一个足以插入锯刀的孔。用铣刀或锉刀处理一下孔，以使锯刀可以与切线齐平。

将固定螺丝 (16) 放到平行限制器的另一侧。通过底板的导引 (12) 推动平行限制器的刻度。在工件待锯切开口的中央位置钻一个孔。将定心尖 (18) 插入平行限制器的内孔和钻好的孔中。根据底板内缘调整半径的刻度值。拧紧固定螺丝 (16)。

冷却剂/润滑剂

锯割金属时由于物料会变热，必须沿着锯割线涂抹冷却剂或润滑剂。

维修和服务

维修和清洁

▶ 在电动工具上进行所有操作之前都必须从插座上拔出电源插头。

▶ 电动工具和通气孔必须随时保持清洁，以确保工作效率和工作安全。

如果必须更换连接线，务必把这项工作交给Bosch或者经授权的Bosch电动工具顾客服务执行，以避免危害机器的安全性能。

定期清洁锯片接头。此时必须先电动工具中拆下锯片，然后在平坦的表面上轻敲电动工具，以便抖落污垢。

电动工具如果沾满污垢，可能会影响机器的功能。因此，请勿从下方或在头顶上切割会产生大量粉尘的材料。

▶ 在某些极端使用环境下，如果可能的话一定要使用吸尘器。经常吹除通气孔中的污垢，并且要使用故障电流保护开关 (PRCD)。加工金属时可能在电动工具的内部堆积会导电的粉尘。这样可能会影响电动工具的安全绝缘性能。

适时地用一滴油润滑导引轮 (9)。

定期检查导引轮(9)。如果已磨损，必须让经过授权的Bosch客户服务中心更换。

客户服务和应用咨询

本公司顾客服务处负责回答有关本公司产品的修理、维护和备件的问题。备件的展开图纸和信息也可查看：www.bosch-pt.com

博世应用咨询团队乐于就我们的产品及其附件问题提供帮助。

询问和订购备件时，务必提供机器铭牌上标示的10位数物品代码。

香港和澳门特别行政区

罗伯特博世有限公司
香港北角英皇道625号，21楼
客户服务热线：+852 2101 0235
传真：+852 2590 9762
电子邮件：info@hk.bosch.com
www.bosch-pt.com.hk

中国大陆

博世电动工具 (中国)
有限公司 中国 浙江省 杭州市
滨江区 滨康路567号
102/1F 服务中心
邮政编码：310052
电话：(0571)8887 5566 / 5588
传真：(0571)8887 6688 x 5566# / 5588#
电邮：bsc.hz@cn.bosch.com
www.bosch-pt.com.cn

制造商地址：

Robert Bosch Power Tools GmbH
 罗伯特·博世电动工具有限公司
 70538 Stuttgart / GERMANY
 70538 斯图加特 / 德国

处理废弃物

必须以符合环保要求的方式回收再利用电动工具、附件和包装材料。



请勿将电动工具扔到生活垃圾中！

繁體中文**安全注意事項****電動工具一般安全注意事項**

警告 請詳讀工作臺及電動工具的所有安全警告與使用說明。若不遵照以下列出的指示，將可能導致電擊、著火和 / 或人員重傷。

保存所有警告和說明書以備查閱。

在所有警告中，「電動工具」此一名詞泛指：以市電驅動的（有線）電動工具或是以電池驅動的（無線）電動工具。

工作場地的安全

- ▶ 保持工作場地清潔和明亮。混亂和黑暗的場地會引發事故。
- ▶ 不要在易爆環境，如有易燃液體、氣體或粉塵的環境下操作電動工具。電動工具產生的火花會點燃粉塵或氣體。
- ▶ 讓兒童和旁觀者離開後操作電動工具。注意力不集中會使您失去對工具的控制。

電氣安全

- ▶ 電動工具插頭必須與插座相配。絕不能以任何方式改裝插頭。需接地的電動工具不能使用任何轉換插頭。未經改裝的插頭和相配的插座將減少電擊危險。
- ▶ 避免人體接觸接地表面，如管道、散熱片和冰箱。如果您身體接地會增加電擊危險。
- ▶ 不得將電動工具暴露在雨中或潮濕環境中。水進入電動工具將增加電擊危險。
- ▶ 不得濫用電線。絕不能用電線搬運、拉動電動工具或拔出其插頭。使電線遠離熱源、油、銳利邊

緣或移動零件。受損或纏繞的軟線會增加電擊危險。

- ▶ 當在戶外使用電動工具時，使用適合戶外使用的延長線。適合戶外使用的軟線，將減少電擊危險。
- ▶ 如果在潮濕環境下操作電動工具是不可避免的，應使用剩餘電流動作保護器（RCD）。使用RCD可降低電擊危險。

人身安全

- ▶ 保持警覺，當操作電動工具時關注所從事的操作並保持清醒。當您感到疲倦，或在有藥物、酒精或治療反應時，不要操作電動工具。在操作電動工具時瞬間的疏忽會導致嚴重人身傷害。
- ▶ 使用個人防護裝置。始終佩戴護目鏡。安全裝置，諸如適當條件下使用防塵面具、防滑安全鞋、安全帽、聽力防護等裝置能減少人身傷害。
- ▶ 防止意外起動。確保開關在連接電源和 / 或電池盒、拿起或搬運工具時處於關閉位置。手指放在已接通電源的開關上或開關處於接通時插入插頭可能會導致危險。
- ▶ 在電動工具接通之前，拿掉所有調節鑰匙或扳手。遺留在電動工具旋轉零件上的扳手或鑰匙會導致人身傷害。
- ▶ 手不要伸展得太長。時刻注意立足點和身體平衡。這樣在意外情況下能很好地控制電動工具。
- ▶ 著裝適當。不要穿寬鬆衣服或佩戴飾品。讓您的衣物及頭髮遠離運動部件。寬鬆衣服、佩飾或長髮可能會捲入運動部件中。
- ▶ 如果提供了與排屑、集塵設備連接用的裝置，要確保他們連接完好且使用得當。使用這些裝置可減少塵屑引起的危險。
- ▶ 切勿因經常使用工具所累積的熟練感而過度自信，輕忽工具的安全守則。任何一個魯莽的舉動都可能瞬間造成人員重傷。

電動工具使用和注意事項

- ▶ 不要濫用電動工具，根據用途使用適當的電動工具。選用適當設計的電動工具會使您工作更有效、更安全。
- ▶ 如果開關不能開啟或關閉工具電源，則不能使用該電動工具。不能用開關來控制的電動工具是危險的且必須進行修理。
- ▶ 在進行任何調整、更換配件或貯存電動工具之前，必須從電源上拔掉插頭並 / 或取出電池盒。這種防護性措施將減少工具意外起動的危險。

- ▶ 將閒置不用的電動工具貯存在兒童所及範圍之外，並且不要讓不熟悉電動工具或對這些說明不瞭解的人操作電動工具。電動工具在未經培訓的用戶手中是危險的。
- ▶ 保養電動工具與配備。檢查運動件是否調整到位或卡住，檢查零件破損情況和影響電動工具運行的其他狀況。如有損壞，電動工具應在使用前修理好。許多事故由維護不良的電動工具引發。
- ▶ 保持切削刀具鋒利和清潔。保養良好的有鋒利切削刃的刀具不易卡住而且容易控制。
- ▶ 按照使用說明書，考慮作業條件和進行的作業來使用電動工具、配件和工具的刀頭等。將電動工具用於那些與其用途不符的操作可能會導致危險。
- ▶ 把手及握持區應保持乾燥、潔淨，且不得沾染任何油液或油脂。易滑脫的把手及握持區將無法讓您在發生意外狀況時安全地抓緊並控制工具。

檢修

- ▶ 將您的電動工具送交專業維修人員，必須使用同樣的備件進行更換。這樣將確保所維修的電動工具的安全性。

線鋸機安全注意事項

- ▶ 進行作業時，負責進行切割的配件可能會碰觸到隱藏的配線或電動工具的電線，請從絕緣處把處拿持電動工具。負責進行切割的配件若是觸及「導電」電線，可能導致電動工具外露的金屬部件「導電」，進而使操作人員遭受電擊。
- ▶ 請用夾具或其他可行方式將工件穩固地架在可靠平台上。用手握持工件或將它貼靠在您身上會因無法確實固定而導致失控。
- ▶ 雙手必須遠離鋸割範圍，手不可以握在工件下端。如果不小心碰觸了鋸片可能被割傷。
- ▶ 先啟動電動工具後再把工具放置在工件上切割。如果電動工具被夾在工件中，會有反彈的危險。
- ▶ 請注意：進行鋸切時，請將底座穩固地貼靠在平面上。鋸片如果歪斜，則可能斷裂或造成反彈。
- ▶ 工作告一段落時，必須先關閉電動工具並等待機器完全靜止後，才可以從鋸縫中抽出鋸刀。如此不但可以防止反彈，而且可以防止放置機器時發生危險。
- ▶ 必須等待電動工具完全靜止後才能將它放下。嵌件工具可能卡住而使電動工具失控。

- ▶ 只能使用未受損、功能正常的鋸片。彎曲或變鈍的鋸片可能斷裂，對鋸痕造成負面影響或導致反彈。
- ▶ 關機後不可以側壓刀片來制止仍然繼續轉動的刀片。鋸刀可能因此受損、斷裂或者造成反彈。
- ▶ 使用合適的偵測裝置偵察隱藏的電線，或者向當地的相關單位尋求支援。接觸電線可能引起火災並讓操作者觸電。若損壞瓦斯管會引起爆炸。鑿穿水管不僅會造成嚴重的財物損失，也可能導致觸電。

產品和功率描述



請詳讀所有安全注意事項和指示。如未遵守安全注意事項與指示，可能導致火災、人員遭受電擊及 / 或重傷。
請留意操作說明書中最前面的圖示。

依規定使用機器

本機器可以在穩固的底墊上，進行切割、挖割。適用的材料包括木材、塑膠、金屬、陶片和橡膠等。本機器不僅能夠鋸切直線，也可以鋸切曲線。請使用本公司推薦的鋸片。

插圖上的機件

機件的編號和電動工具詳解圖上的編號一致。

- (1) 用以退出鋸片的 SDS 旋轉蓋
- (2) 起停開鎖扣
- (3) 起停開關
- (4) 衝擊次數設定轉鈕
- (5) 底座
- (6) 鋸屑噴吹開關
- (7) 振蕩調整桿
- (8) 鋸片座
- (9) 導引輪
- (10) 鋸片^{A)}
- (11) 保護遮罩
- (12) 平行擋塊的導軌
- (13) 防割傷裝置
- (14) 把手（絕緣握柄）
- (15) 防毛邊壓板^{A)}
- (16) 平行擋塊的止付螺絲^{A)}
- (17) 附帶割圓輔助器的平行擋塊^{A)}
- (18) 割圓輔助器的圓心尖端^{A)}

A) 圖表或說明上提到的配件，並不包含在基本的供貨範圍中。本公司的配件清單中有完整的配件供應項目。

技術性數據

線鋸機		GST 25 M
產品機號		3 601 E16 ...
衝擊次數調控		●
電子穩定控制系統		●
額定輸入功率	W	670
無負載轉速 n_0	min^{-1}	500-2600
衝程	mm	24
最大鋸切深度		
- 在木材上	mm	80
- 在鋁材上	mm	25
- 在鋼材上 (非合金)	mm	15
重量符合 EPTA-Procedure 01:2014	kg	2.7
絕緣等級		□/□

本說明書提供的參數是以 230 伏特為依據，於低電壓地區，此數據有可能不同。

安裝

- ▶ **維修電動工具或換裝零、配件之前，務必從插座上拔出插頭。**

安裝 / 更換鋸片

- ▶ **安裝或更換嵌件工具時務必穿戴防護手套。** 嵌件工具極為銳利，而且長時間使用後可能發燙。

選擇鋸片

本說明書的最後面另外刊錄了建議使用之鋸片一覽表。僅能裝入單耳柄鋸片 (T 柄鋸片)。鋸片長度不得超過預定鋸線。

在狹小的彎角上鋸切時應要使用窄型鋸片。

安裝 / 取出鋸片 (請參考圖 A)

- ▶ **請於裝入前清潔鋸片柄部。** 柄部若髒污即無法牢固固定。

- ① 將 SDS 旋轉蓋 (1) 往上拉。
- ② 將 SDS 旋轉蓋 (1) 逆時針旋轉 3 圈左右，將之解鎖。
- ③ 讓鋸片 (10) 與鋸切方向呈交叉垂直狀，然後插進鋸片座 (8) 中。
- ④ 旋轉鋸片 (10)，使鋸齒朝鋸切方向。請注意：鋸片刀背應要位於導引輪 (9) 的溝槽內。
- ⑤ 順時針旋轉 SDS 旋轉蓋 (1)，直到發出越過制動卡桿的軋軋聲。

- ⑥ 順時針旋轉 SDS 旋轉蓋 (1)，直到其回到初始位置。將 SDS 旋轉蓋往下推至位置鎖定為止。

- ▶ **檢查鋸片是否已經裝牢。** 鬆動的鋸刀可能掉落並造成您受傷。

請按相反順序拆卸鋸片。

防毛邊壓板 (請參考圖 B)

防毛邊壓板 (15) (配件) 可在鋸切木材時防止工件表面被扯裂。防毛邊壓板僅適用於特定種類鋸片。

從下方將防毛邊壓板 (15) 壓進底座 (5) 內。

吸鋸塵 / 吸鋸屑

含鉛的顏料及部分木材、礦物和金屬的加工廢塵有害健康。機器操作者或者工地附近的人如果接觸、吸入這些廢塵，可能會有過敏反應或者感染呼吸道疾病。

特定粉塵 (例如加工橡木或山毛櫸的廢塵) 可能致癌，特別是與處理木材的添加劑 (例如木材的防腐劑等) 混合之後。只有經過專業訓練的人才允許加工含石棉的物料。

- 工作場所要保持空氣流通。

- 建議佩戴 P2 濾網等級的口罩。

請留意並遵守貴國與加工物料有關的法規。

- ▶ **避免讓工作場所堆積過多的塵垢。** 塵埃容易被點燃。

保護遮罩 (請參考圖 C)

金屬鋸屑不但溫度極高且邊緣銳利，可能造成人員受傷。因此，加工金屬或鋁材時，請您裝上保護遮罩 (11)。

將保護遮罩 (11) 套在電動工具上，使固定座卡入至防割傷裝置 (13) 上。

加工木材時，請您拆下保護遮罩 (11)。此時，請您將保護遮罩往前從防割傷裝置 (13) 上拔下。

操作

操作模式

- ▶ **維修電動工具或換裝零、配件之前，務必從插座上拔出插頭。**

振蕩功能

振蕩功能可配合加工材質將此裝置調整至最理想的鋸切速度、鋸切效率以及鋸切剖面。

例如鋸切軟質材料或順著木紋鋸切木材時，請開啟振蕩功能。其做法是：將調整桿 (7) 推至「I」位置。即使電動工具正在運轉也能做此調整。

若想要獲取乾淨俐落的鋸切邊緣，或是在加工薄片型材料 (像是金屬片) 時，請關閉振蕩功能。其做法是：將調整桿 (7) 推至「0」位置。

鋸屑噴吹裝置

利用鋸屑噴吹裝置的氣流，即可讓鋸切線保持乾淨，不會堆積塵屑。

在會生成大量塵屑的木材、塑膠等類似材料上進行加工時，請開啟鋸屑噴吹裝置。其做法是：將開關 (6) 推至位置「I」。

當您加工金屬材料時，請關閉鋸屑噴吹裝置。其做法是：將開關 (6) 推至位置「0」。

操作機器

- ▶ **請注意電源電壓！** 電源的電壓必須和電動工具銘牌上標示的電壓一致。標示為 230 V 的電動工具亦可接上 220 V 電源。

啟動 / 關閉電源

- ▶ **請確定您不用放開把手，就能操作起停開關。**

若要**啟動**電動工具：按下起停開關 (3)。

若要**固定**起停開關 (3) 的位置，請將它按住不放並同時將鎖扣 (2) 往右或往左推。

若要**關閉**電動工具，放開起停開關 (3) 即可。起停開關 (3) 的位置若是已被鎖定，請按一下該開關然後放開。

電子穩定控制系統

有了電子穩定控制系統，機器的衝擊次數能夠在空轉和負載時都保持恆定，以確保運作功率保持一致。

控制 / 設定衝擊次數

您可為已啟動的電動工具無段調控轉速，衝擊次數是由按壓起停開關 (3) 的深度而定。

輕按起停開關 (3) 時，衝擊次數較少。按得越緊衝擊次數越多。

起停開關 (3) 的位置被鎖定時，將無法調降衝擊次數。

利用衝擊次數設定轉鈕 (4)，即可按照需求預設衝擊次數並於工具運作期間變更。

正確的衝擊次數必須視工件物料和工作狀況而定。唯有實際操作才能找出最合適的衝擊次數。

將鋸片放到工件上時以及鋸切塑膠、鋁片時，建議您降低衝擊次數。

以較少的衝擊次數長時間加工後，電動工具會變得很快熱。拆下鋸片，讓電動工具以最高衝擊次數運作 3 分鐘以加速冷卻。

作業注意事項

- ▶ **維修電動工具或換裝零、配件之前，務必從插座上拔出插頭。**
- ▶ **如果鋸片被夾住了，請立刻關閉電動工具的電源。**

- ▶ **一律要在穩固平面上加工偏小型或薄片型工件。**

在鋸進木材、塑合板、建材等物的內部前，請先確認有無異物（例如鐵釘、螺絲等），如有必要請將它移除。

潛鋸（請參考圖 D）

- ▶ **僅在加工軟木、石膏板等這類軟性材料時可進行潛鋸！**

潛鋸時只能使用短型鋸片。

將電動工具的底座 (5) 前緣放到工件上，但不要讓鋸片 (10) 接觸到工件，然後啟動機器。如果電動工具備衝擊次數調控功能的話，必須選擇最高衝擊次數。用力地把電動工具壓向工件，並讓鋸片慢慢地潛入工件中。

待底座 (5) 完全貼靠在工件上的時候，便立刻沿著預計完工的鋸割線繼續鋸切。

附帶割圓輔助器的平行擋塊（配件）

使用具有割圓輔助器的平行擋塊 (17)（配件）時，工件厚度不可超過 30 mm。

平行鋸切（請參考圖 E）：鬆開止付螺絲 (16)，然後沿著底座上的導軌 (12) 移動平行擋塊的刻度尺。根據刻度調整好所需鋸切寬度。旋緊止付螺絲 (16)。

割圓（請參考圖 F）：沿著待鋸圓形內側的鋸割線上鑽孔，此孔的寬度應要足以讓鋸片穿過。用銼刀或銼刀加工鑽孔，使鋸片能夠對齊鋸割線。

在平行擋塊的另一側上裝上止付螺絲 (16)。沿著底座上的導軌 (12) 移動平行擋塊的刻度尺。在挖鋸範圍的中央位置鑽孔。將圓心尖端 (18) 穿過平行擋塊的內側開口後，插進之前鑽出的鑽孔。根據底座內緣上的刻度調整好挖鋸範圍的半徑。旋緊止付螺絲 (16)。

冷卻劑 / 潤滑劑

鋸切金屬時由於物料會變熱，必須在鋸割線上塗抹冷卻劑或潤滑劑。

維修和服務

維修和清潔

- ▶ **維修電動工具或換裝零、配件之前，務必從插座上拔出插頭。**
- ▶ **電動工具和通風口都必須保持清潔，這樣才能夠提高工作品質和安全性。**

如果必須更換連接線，請務必交由 **Bosch** 或者經授權的 **Bosch** 電動工具顧客服務執行，以避免危害機器的安全性能。

20 | 한국어

定期清潔鋸片接頭。此時必須先從電動工具中拆下鋸片，並且在平坦表面上輕敲電動工具，以便抖落塵垢。

電動工具如果沾滿污垢，可能會影響機器性能。請勿從下方或從高於頭部的位置鋸切會生成大量粉塵的材料。

- ▶ 在某些極端操作環境下，如果有可能請務必使用吸塵裝備。**時常將通氣孔上累積的塵垢噴吹乾淨，並在前端加設漏電斷路器 (PRCD)**。加工金屬時電動工具內部可能堆積會導電的廢塵。這樣可能會影響電動工具的安全絕緣性能。

適時地用一滴油潤滑導引輪 (9)。

定期檢查導引輪 (9)。如果確定導引輪已經損壞，必須把機器交給經過授權的 **Bosch** 客戶服務中心更換導引輪。

顧客服務處和顧客諮詢中心

本公司顧客服務處負責回答有關本公司產品的維修、維護和備用零件的問題。以下的網頁中有分解圖和備用零件相關資料：www.bosch-pt.com

如果對本公司產品及其配件有任何疑問，博世應用諮詢小組很樂意為您提供協助。

當您需要諮詢或訂購備用零件時，請務必提供本產品型號銘牌上 10 位數的產品機號。

中國香港和澳門特別行政區

羅伯特·博世有限公司
香港北角英皇道625號21樓
客戶服務熱線: +852 2101 0235
傳真: +852 2590 9762
電子郵件: info@hk.bosch.com
www.bosch-pt.com.hk

台灣

台灣羅伯特博世股份有限公司
建國北路一段90號6樓
台北市10491
電話: (02) 7734 2588
傳真: (02) 2516 1176
www.bosch-pt.com.tw

製造商地址:

Robert Bosch Power Tools GmbH
羅伯特·博世電動工具有限公司
70538 Stuttgart / GERMANY
70538 斯圖加特/ 德國

廢棄物處理

必須以符合環保的方式，回收再利用損壞的機器、配件和廢棄的包裝材料。



不可以把電動工具丟入一般的家庭垃圾中。

設備名稱：線鋸機，型號：GST 25 M

限用物質及其符號

單元	鉛 (Pb)	汞 (Hg)	鎘 (Cd)	六價鉻 (Cr ⁺⁶)	多溴聯苯 (PBB)	多溴二苯醚 (PBDE)
開關	○	○	○	○	○	○
電容器	○	○	○	○	○	○
馬達	○	○	○	○	○	○
電源線	○	○	○	○	○	○
外殼(塑料)	○	○	○	○	○	○
外殼(金屬)	○	○	○	○	○	○
調速器	○	○	○	○	○	○

備考 1. "超出 0.1 wt %" 及 "超出 0.01 wt %" 係指限用物質之百分比含量超出百分比含量基準值。

備考 2. "○" 係指該項限用物質之百分比含量未超出百分比含量基準值。

備考 3. "-" 係指該項限用物質為排除項目。

한국어

안전 수칙

전동공구 일반 안전 수칙

경고

본 전동공구와 함께 제공된 모든 안전경고, 지시사항, 그림 및

사양을 숙지하십시오. 다음의 지시 사항을 준수하지 않으면 감전, 화재, 또는 심각한 부상을 초래할 수 있습니다.

앞으로 참고할 수 있도록 이 안전수칙과 사용 설명서를 잘 보관하십시오.

다음에서 사용되는 "전동공구"라는 개념은 전원에 연결하여 사용하는 (전선이 있는) 전동 기기나 배터리를 사용하는 (전선이 없는) 전동 기기를 의미합니다.

작업장 안전

- ▶ **작업장을 항상 깨끗이 하고 조명을 밝게 하십시오.** 작업장 환경이 어수선하거나 어두우면 사고를 초래할 수 있습니다.
- ▶ **가연성 유체, 가스 또는 분진이 있어 폭발 위험이 있는 환경에서 전동공구를 사용하지 마십시오.** 전동공구는 분진이나 증기에 점화하는 스파크를 일으킬 수 있습니다.
- ▶ **전동공구를 사용할 때 구경꾼이나 어린이 혹은 다른 사람이 작업장에 접근하지 못하게 하십시오.** 다른 사람이 주의를 산만하게 하면 기기에 대한 통제력을 잃기 쉽습니다.

전기에 관한 안전

- ▶ **전동공구의 전원 플러그가 전원 콘센트에 잘 맞아야 합니다.** 플러그를 절대 변경시켜서는 안 됩니다. (접지된) 전동공구를 사용할 때 어댑터 플러그를 사용하지 마십시오. 변형되지 않은 플러그와 잘 맞는 콘센트를 사용하면 감전의 위험을 줄일 수 있습니다.
- ▶ **파이프 관, 라디에이터, 레인지, 냉장고와 같은 접지 표면에 몸이 닿지 않도록 하십시오.** 몸에 닿을 경우 감전될 위험이 높습니다.
- ▶ **전동공구를 비에 맞지 않게 하고 습기 있는 곳에 두지 마십시오.** 전동공구에 물이 들어가면 감전될 위험이 높습니다.
- ▶ **전원 코드를 잘못 사용하는 일이 없도록 하십시오.** 전원 코드를 잡고 전동공구를 운반해서는 안 되며, 콘센트에서 전원 플러그를 뽑을 때 전원 코드를 잡아 당겨서는 절대로 안 됩니다. 전원 코드가 열과 오일에 접촉하는 것을 피하고, 날카로운 모서리나 기기의 가동 부위에 닿지 않도록 주의 하십시오. 손상되거나 영긴 전원 코드는 감전을 유발할 수 있습니다.
- ▶ **실외에서 전동공구로 작업할 때는 실외용으로 적당히 연장 전원 코드만을 사용하십시오.** 실외용 연장 전원 코드를 사용하면 감전의 위험을 줄일 수 있습니다.
- ▶ **전동공구를 습기 찬 곳에서 사용해야 할 경우에는 누전 차단기를 사용하십시오.** 누전 차단기를 사용하면 감전 위험을 줄일 수 있습니다.

사용자 안전

- ▶ **신중하게 작업하며, 전동공구를 사용할 때 경솔하게 행동하지 마십시오.** 피로한 상태이거나 약물 복용 및 음주한 후에는 전동공구를 사용하지 마십시오. 전동공구를 사용할 때 잠시라도 주의가 산만해지면 중상을 입을 수 있습니다.
- ▶ **작업장 안전을 위한 장치를 사용하십시오.** 항상 보안경을 착용하십시오. 전동공구의 종류와 사용에 따라 먼지 보호 마스크, 미끄러지지 않는 안전화, 안전모 또는 귀마개 등의 안전한 복장을 하면 상해의 위험을 줄일 수 있습니다.
- ▶ **실수로 기기가 작동되지 않도록 주의하십시오.** 전동공구를 전원에 연결하거나 배터리를 끼우기 전에, 혹은 기기를 들거나 운반하기 전에, 전원 스위치가 꺼져 있는지 다시 확인하십시오. 전동공구를 운반할 때 전원 스위치가 손가락을 대거나

전원 스위치가 켜진 상태에서 전원을 연결하면 사고 위험이 높습니다.

- ▶ **전동공구를 사용하기 전에 조절하는 틀이나 키텔을 빼 놓으십시오.** 회전하는 부위에 있는 틀이나 키로 인해 상처를 입을 수 있습니다.
- ▶ **자신을 과신하지 마십시오.** 불안정한 자세를 피하고 항상 평형을 이룬 상태로 작업하십시오. 안정된 자세와 평형한 상태로 작업해야만이 의외의 상황에서도 전동공구를 안전하게 사용할 수 있습니다.
- ▶ **알맞은 작업복을 입으십시오.** 헐렁한 복장을 하거나 장신구를 착용하지 마십시오. 머리카락이나 옷이 가동하는 기기 부위에 가까이 닿지 않도록 주의 하십시오. 헐렁한 복장, 장신구 혹은 긴 머리는 가동 부위에 말려 사고를 초래할 수 있습니다.
- ▶ **분진 추출장치나 수거장치의 조립이 가능한 경우, 이 장치가 연결되어 있는지, 제대로 작동이 되는지 확인하십시오.** 이러한 분진 추출장치를 사용하면 분진으로 인한 사고 위험을 줄일 수 있습니다.
- ▶ **틀을 자주 사용한다고 해서 안주하는 일이 없게 하고 공구의 안전 수칙을 무시하지 않도록 하십시오.** 부주의하게 취급하여 순간적으로 심각한 부상을 입을 수 있습니다.

전동공구의 올바른 사용과 취급

- ▶ **기기를 과부하 상태에서 사용하지 마십시오.** 작업할 때 이에 적당한 전동공구를 사용하십시오. 알맞은 전동공구를 사용하면 지정된 성능 한도 내에서 더 효율적으로 안전하게 작업할 수 있습니다.
- ▶ **전원 스위치가 고장 난 전동공구를 사용하지 마십시오.** 전원 스위치가 작동되지 않는 전동공구는 위험하므로, 반드시 수리를 해야 합니다.
- ▶ **전동공구를 조정하거나 액세서리 부품 교환 혹은 공구를 보관할 때, 항상 전원 콘센트에서 플러그를 미리 빼어 놓거나 배터리를 분리하십시오.** 이러한 조치는 실수로 전동공구가 작동하게 되는 것을 예방합니다.
- ▶ **사용하지 않는 전동공구는 어린이 손이 닿지 않는 곳에 보관하고, 전동공구 사용에 익숙지 않거나 이 사용 설명서를 읽지 않은 사람은 기기를 사용해서는 안 됩니다.** 경험이 없는 사람이 전동공구를 사용하면 위험합니다.
- ▶ **전동공구 및 액세서리를 조심스럽게 관리하십시오.** 가동 부위가 하자 없이 정상적인 기능을 하는지, 걸리는 부위가 있는지, 혹은 전동공구의 기능에 중요한 부품이 손상되지 않았는지 확인하십시오. 손상된 기기의 부품은 전동공구를 다시 사용하기 전에 반드시 수리를 맡기십시오. 제대로 관리하지 않은 전동공구의 경우 많은 사고를 유발합니다.
- ▶ **절단 공구를 날카롭고 깨끗하게 관리하십시오.** 날카로운 절단면이 있고 잘 관리된 절단공구는 걸리는 경우가 드물고 조절하기도 쉽습니다.
- ▶ **전동공구, 액세서리, 장착하는 공구 등을 사용할 때, 이 지시 사항과 특별히 기종 별로 나와있는 사용 방법을 준수하십시오.** 이때 작업 조건과 실시

하려는 작업 내용을 고려하십시오. 원래 사용 분야가 아닌 다른 작업에 전동공구를 사용할 경우 위험한 상황을 초래할 수 있습니다.

- ▶ **손잡이 및 잡는 면을 건조하게 유지하고, 오일 및 그리스가 묻어 있지 않도록 깨끗하게 하십시오.** 손잡이 또는 잡는 면이 미끄러우면 예상치 못한 상황에서 안전한 취급 및 제어가 어려워집니다.

서비스

- ▶ **전동공구 수리는 반드시 전문 인력에게 맡기고, 수리 정비 시 보쉬 순정 부품만을 사용하십시오.** 그렇게 함으로써 기기의 안전성을 오래 유지할 수 있습니다.

직소 관련 안전 수칙

- ▶ **절단용 액세스리가 숨겨진 배선 또는 코드를 접촉할 가능성이 있는 작업을 수행할 경우, 전동공구의 절연된 손잡이 면만 잡으십시오.** 절단용 액세스리가 "전류가 흐르는" 전선에 접촉되면, 전동공구의 노출된 금속 부품에 "전류가 흐르는" 상태로 만들어 작업자가 감전될 수 있습니다.
- ▶ **클램프 등을 사용하여 가공물을 작업대에 안전하게 고정하고 받쳐주십시오.** 가공물을 손으로 잡거나 몸쪽을 향하도록 잡으면 불안정한 상태가 되어 통제력을 잃을 수도 있습니다.
- ▶ **톱 쪽으로 손을 가까이 대지 마십시오.** 작업물의 아래쪽을 잡지 마십시오. 톱날과 접하게 되면 부상을 입을 수 있습니다.
- ▶ **전동공구를 켜 상태에서만 작업물에 서서히 접근하십시오.** 그렇지 않으면 톱날이 작업물에 걸리면서 반동이 생길 위험이 있습니다.
- ▶ **톱 작업 시 밀판이 안전하게 밀착되어 있는지 확인하십시오.** 톱날이 걸려 있으면 부러지거나 반동이 생길 수 있습니다.
- ▶ **작업을 마치고 나서 전동공구의 전원을 끄고 기기가 완전히 정지된 후에 절단면에서 톱날을 빼내십시오.** 이렇게 하면 반동이 생기는 것을 방지할 수 있으며 전동공구를 안전하게 내려 놓을 수 있습니다.
- ▶ **전동공구를 내려놓기 전에 기기가 완전히 멈추었는지 확인하십시오.** 삽입공구가 걸리거나 전동공구에 대한 통제가 어려워질 수 있습니다.
- ▶ **반드시 손상되지 않고 결함이 없는 톱날만 사용하십시오.** 휘거나 날카롭지 않은 톱날이 부러져 절단 작업을 방해하거나 반동을 유발할 수 있습니다.
- ▶ **전원을 끈 후 옆에서 톱날을 눌러 정지해서는 안 됩니다.** 이로 인해 톱날이 손상되거나 부러질 수 있으며 혹은 반동을 유발할 수 있습니다.
- ▶ **보이지 않는 부위에 에너지 배선 및 배관 여부를 확인하려면 적당한 탐지기를 사용하거나 담당 전력 공급회사에 문의하십시오.** 전선에 접하게 되면 화재나 전기 충격을 야기할 수 있습니다. 가스관을 손상시키면 폭발 위험이 있습니다. 수도관을 파손하게 되면 재산 피해를 유발하거나 전기 충격을 야기할 수 있습니다.

제품 및 성능 설명



모든 안전 수칙과 지침을 숙지하십시오. 다음의 안전 수칙과 지침을 준수하지 않으면 화재 위험이 있으며 감전 혹은 중상을 입을 수 있습니다.

사용 설명서 앞 부분에 제시된 그림을 확인하십시오.

규정에 따른 사용

본 전동공구는 목재, 플라스틱, 금속, 세라믹판 그리고 고무 재제를 단단한 작업대 위에 고정시킨 상태에서 절단선을 긋는 작업이나 절단작업을 하는 데 사용해야 합니다. 직선 및 곡선 절단 작업에 적합합니다. 톱날 선택에 대한 권장 자료를 참고하십시오.

제품의 주요 명칭

제품의 주요 명칭에 표기되어 있는 번호는 기기 그림이 나와있는 면을 참고하십시오.

- (1) 톱날 해제용 SDS 회전 캡
- (2) 전원 스위치 잠금 버튼
- (3) 전원 스위치
- (4) 스트로크 수 설정용 조절 휠
- (5) 밀판
- (6) 톱밥 분출장치 스위치
- (7) 오비탈 작동 조절 레버
- (8) 톱날 홀더
- (9) 가이드 롤러
- (10) 톱날^{A)}
- (11) 먼지 커버
- (12) 평행 가이드용 리드
- (13) 안전핀
- (14) 손잡이(절연된 손잡이 부위)
- (15) 작업 표면 보호대^{A)}
- (16) 평행 가이드 잠금 나사^{A)}
- (17) 원형 절단기가 있는 평행 가이드^{A)}
- (18) 원형 절단기의 중심 표시기^{A)}

A) 도면이나 설명서에 나와있는 액세스러리는 표준 공급부품에 속하지 않습니다. 전체 액세스러리는 저희 액세스러리 프로그램을 참고하십시오.

제품 사양

직소	GST 25 M	
제품 번호	3 601 E16 ...	
스트로크 수 제어		●
일정 속도 전자 제어 장치		●
소비 전력	W	670
공회전 스트로크 수 n ₀	min ⁻¹	500-2600
스트로크	mm	24
최대 절단 깊이		

직소		GST 25 M
- 목재	mm	80
- 알루미늄	mm	25
- 강(비합금)	mm	15
EPTA-Procedure 01:2014에 따른 중량	kg	2.7
보호 등급		□/

자료는 정격 전압 [U] 230 V를 기준으로 한 것입니다. 전압이 다른 경우 및 국가별 사양에 따라 변동이 있을 수 있습니다.

조립

- ▶ 전동공구를 보수 정비하기 전에 반드시 콘센트에서 전원 플러그를 빼십시오.

톱날 끼우기/교환하기

- ▶ 톱날을 조립 또는 교체할 경우 보호 잠금을 착용하십시오. 톱날은 날카로우며, 장시간 사용하면 뜨거워질 수 있습니다.

톱날 선택하기

추천하는 톱날 목록은 본 설명서의 마지막 부분에 나와 있습니다. 옆 돌출턱이 1개인 톱날(T자형)만 사용하십시오. 톱날은 절단하려는 깊이보다 길어서는 안 됩니다.

좁은 모서리 절단 시 가는 톱날을 사용하십시오.

톱날 끼우기/분리하기(그림 A 참조)

- ▶ 톱날을 끼우기 전에 톱날의 생크를 깨끗이 닦으십시오. 생크가 깨끗하지 않으면, 안전하게 고정되지 않을 수 있습니다.

- 1 SDS 회전 캡 (1) 을 위쪽으로 당기십시오.
- 2 잠금을 해제하려면 SDS 회전 캡 (1) 을 약 3 바퀴 정도 시계 반대 방향으로 돌리십시오.
- 3 톱날 (10) 을 절단 방향의 가로 방향으로 톱날 홀더 (8) 에 끼우십시오.
- 4 톱날 (10) 을 돌려 톱니가 절단 방향을 향하게 하십시오. 등 부위가 가이드 롤러 (9) 의 홈에 위치하도록 하십시오.
- 5 SDS 회전 캡 (1) 이 과부하 걸리기 전까지 시계 방향으로 돌리십시오.
- 6 SDS 회전 캡 (1) 이 과부하가 초기 위치로 돌아올 때까지 계속 시계 방향으로 돌리십시오. SDS 회전 캡을 잠그려면 아래쪽으로 미십시오.

- ▶ 톱날이 제대로 끼워졌는지 확인해 보십시오. 느슨하게 걸린 톱날은 빠질 수 있으며 이로 인해 작업자가 상해를 입을 수 있습니다.

톱날을 분리하려면 반대 순서로 하면 됩니다.

작업 표면 보호대(그림 B 참조)

작업 표면 보호대 (15) (액세서리)는 목재를 톱질할 때 표면이 손상되는 것을 방지해줍니다. 작업 표면 보호대는 특정 유형의 톱날에서만 사용할 수 있습니다.

작업 표면 보호대 (15) 를 아래쪽에서 밀판 (5) 에 눌러 끼우십시오.

분진 및 톱밥 추출장치

납 성분을 포함한 페인트나 몇몇 나무 종류, 또는 광물 성분 그리고 철과 같은 재료의 분진은 건강을 해칠 수 있습니다. 이 분진을 만지거나 호흡할 경우, 사용자나 주변 사람들은 알레르기 반응이나 호흡기 장애를 일으킬 수 있습니다.

떡갈나무나 너도밤나무와 같은 특정한 분진은 암을 유발시키며, 특히 목재 처리용으로 사용되는 부가 원료(크로마트, 목재 보호제)와 혼합되면 암을 유발시키게 됩니다. 석면 성분을 포함한 재료는 오직 전문가가 작업을 해야 합니다.

- 작업장의 통풍이 잘 되도록 하십시오.
- 필터등급 P2에 해당되는 호흡 마스크를 사용하십시오.

작업용 재료에 관해 국가가 지정한 규정을 고려하십시오.

- ▶ 작업장에 분진이 쌓이지 않도록 하십시오. 분진이 쉽게 발화할 수 있습니다.

먼지 커버(그림 C 참조)

모서리가 날카롭고 금속 칩이 뜨거워 이로 인해 부상을 입을 위험이 있습니다. 따라서 금속 또는 알루미늄에서 작업하려면 먼지 커버 (11) 를 장착하십시오.

먼지 커버 (11) 를 전동공구에 설치하여 홀더가 안전핀 (13) 에 맞물려 고정될 수 있게 하십시오.

목재에서 작업할 경우 먼지 커버 (11) 를 분리하십시오. 분리하려면 안전핀 (13) 에서 앞쪽으로 빼내십시오.

작동

작동 모드

- ▶ 전동공구를 보수 정비하기 전에 반드시 콘센트에서 전원 플러그를 빼십시오.

오비탈 작동

오비탈 작동이 작업하려는 소재에 맞춰 절단 속도, 절단 성능, 절단 모양을 결정할 수 있습니다.

예를 들어 부드러운 소재에서 톱 작업 및 목재에서 결 방향으로 톱 작업하는 경우 오비탈 작동을 켜십시오. 이를 위해 조절 레버 (7) 를 "I" 위치로 미십시오. 작동하는 도중에도 가능합니다.

절단 모서리가 미세하고 깔끔한 경우 및 얇은 작업물(예: 철판) 가공 시 오비탈 작동을 끄십시오. 이를 위해 조절 레버 (7) 를 "0" 위치로 미십시오.

톱밥 분출장치

톱밥 분출장치의 배출 작업을 통해 절단선에 톱밥이 남아 있지 않게 할 수 있습니다.

목재, 플라스틱 등 톱밥 배출량이 큰 작업을 할 수 있도록 톱밥 분출장치를 켜십시오. 이를 위해 스위치 (6) 를 "I" 위치로 미십시오.

금속에서 작업할 수 있도록 톱날 분출장치 끄십시오. 이를 위해 스위치 (6) 를 “0” 위치로 미십시오.

기계 시동

- ▶ **전원의 전압에 유의하십시오! 공급되는 전원의 전압은 전동공구의 명판에 표기된 전압과 동일해야 합니다. 230 V 로 표시된 전동공구는 220 V 에서도 작동이 가능합니다.**

전원 스위치 작동

- ▶ **손잡이에서 손을 떼지 않고 전원 스위치를 작동할 수 있는지 확인하십시오.**

전동공구의 전원을 켜려면 전원 스위치 (3) 를 누르십시오.

전원 스위치 (3) 를 고정시키려면 전원 스위치를 누른 상태에서 잠금 버튼 (2) 을 좌측 또는 우측으로 미십시오.

전동공구의 전원을 끄려면 전원 스위치 (3) 에서 손을 떼십시오. 전원 스위치 (3) 가 고정된 상태에서 먼저 전원 스위치를 눌렀다가 전원 스위치에서 손을 떼십시오.

일정 속도 전자 제어 장치

일정 속도 전자제어장치는 무부하 시나 부하 시의 회전 속도를 거의 일정하게 유지하여 동일한 작업 결과를 보장합니다.

스트로크 수 조절하기/설정하기

전원 스위치 (3) 를 밀어 이동시키는 만큼 전원이 켜진 전동공구의 스트로크 수를 조절할 수 있습니다.

전원 스위치 (3) 를 약간만 밀면 스트로크 수가 낮아집니다. 세게 누르면 스트로크 수가 높아집니다.

전원 스위치 (3) 가 잠긴 상태에서는 스트로크 수를 줄일 수 없습니다.

스트로크 수 설정용 조정 휠 (4) 을 이용해 스트로크 수를 사전 설정하고 작동하면서 변경할 수 있습니다.

작업 소재와 작업 조건에 따라 필요로 하는 스트로크 수가 달라지므로 실제 시험을 통해 결정할 수 있습니다.

톱날을 작업물에 대거나 플라스틱과 알루미늄에 톱 작업을 할 때 스트로크 수를 줄이는 것이 좋습니다. 낮은 속도로 장시간 작업할 경우 전동공구가 과열될 수 있습니다. 이 경우 톱날을 빼고 전동공구를 식히기 위해 최대 속도로 약 3 분간 작동시켜 주십시오.

사용 방법

- ▶ **전동공구를 보수 정비하기 전에 반드시 콘센트에서 전원 플러그를 빼십시오.**
- ▶ **톱날이 물리면 즉시 전동공구 스위치를 끄십시오.**
- ▶ **크기가 작거나 얇은 소재를 가공하는 경우 항상 견고한 받침대를 사용하십시오.**

목재, 칩보드, 건축용 자재 등에서 톱 작업하기 전에 해당 소재에 못, 나사 등과 같은 이물질이 없는지 점검하고, 필요에 따라 이를 제거하십시오.

플런지 쏘(그림 D 참조)

- ▶ **연목, 석고보드와 같은 연질 소재의 경우에만 플런지 절단 방식으로 가공할 수 있습니다!**

플런지 절단 작업 시에는 짧은 톱날만 사용하십시오.

전동공구를 밀판 (5) 의 앞쪽 가장자리와 함께 가공물에 설치하십시오. 이때 톱날 (10) 이 가공물을 건드리지 않게 유의하고, 전동공구의 전원을 켜십시오. 스트로크 수 제어장치가 있는 전동공구의 경우 최대 값으로 선택하십시오. 전동공구를 작업물에 대고 누르고 톱날을 천천히 작업물 안으로 들어가게 합니다.

밀판 (5) 이 가공물의 전체 표면에 닿으면, 원하는 절단선을 따라 절단 작업을 진행합니다.

원형 절단기가 있는 평행 가이드(액세서리)

원형 절단기가 있는 평행 가이드 (17) (액세서리)를 이용해 작업하는 경우 작업물의 두께는 최대 30 mm를 초과할 수 없습니다.

평행 절단(그림 E 참조): 잠금 나사 (16) 를 풀고 밀판에서 평행 가이드의 눈금을 리드 (12) 를 통해 미십시오. 원하는 절단 너비가 밀판의 안쪽 모서리 눈금자에 나타나도록 설정하십시오. 잠금 나사 (16) 를 돌려 조이십시오.

원형 절단(그림 F 참조): 톱 작업해야 할 원 안에 절단선을 따라 구멍을 뚫어 톱날이 들어갈 수 있게 하십시오. 홀 작업 시 루터 또는 줄을 이용하여 톱날이 절단선에 밀착되게 하십시오.

잠금 나사 (16) 를 평행 가이드의 다른 측면에 설치하십시오. 밀판에서 평행 가이드의 눈금을 리드 (12) 를 관통하여 미십시오. 작업물에 톱질하여 내려 내려는 부위 중심에 구멍을 냅니다. 중심 표시기 (18) 를 평행 가이드 안쪽 구멍 및 뚫은 구멍에 끼우십시오. 반경이 밀판의 안쪽 모서리 눈금자에 나타나도록 설정하십시오. 잠금 나사 (16) 를 돌려 조이십시오.

냉각제/윤활제

금속에 톱질 작업을 할 때 작업물이 과열되기 때문에 절단선을 따라 냉각제나 윤활제를 발라 주어야 합니다.

보수 정비 및 서비스

보수 정비 및 유지

- ▶ **전동공구를 보수 정비하기 전에 반드시 콘센트에서 전원 플러그를 빼십시오.**
- ▶ **안전하고 올바른 작동을 위하여 전동공구와 전동공구의 통풍구를 항상 깨끗이 하십시오.**

연결 코드를 교환해야 할 경우 안전을 기하기 위해 **Bosch** 또는 **Bosch** 지정 전동공구 서비스 센터에 맡겨야 합니다.

톱날 홀더를 정기적으로 닦아 주십시오. 이 경우 톱날을 전동공구에서 빼내고 전동공구를 평면에 가볍게 두드려 털어 주십시오.

전동공구가 지나치게 오염되어 있으면 기능 장애가 생길 수 있습니다. 따라서 본진이 많이 배출되는 소

재는 아래쪽 또는 머리 위쪽에서 작업하지 마십시오.

▶ **작동 조건이 열악한 경우에는 가능한 항상 집진 장치를 사용하십시오. 통풍구를 자주 청소하고 누전 차단기 (PRCD)에 연결하십시오.** 금속 소재에서 작업할 경우 전도성 분진이 전동공구 안에 쌓일 수 있습니다. 이로 인해 전동공구의 보호 절연장치 기능에 장애가 생길 수 있습니다.

가이드 롤러 (9) 에 가끔 오일 한 방울을 발라 주십시오

가이드 롤러 (9) 를 정기적으로 점검하십시오. 마모된 경우, **Bosch** 지정 서비스 센터에 맡겨 교환해 주어야 합니다.

AS 센터 및 사용 문의

AS 센터에서는 귀하 제품의 수리 및 보수정비, 그리고 부품에 관한 문의를 받고 있습니다. 대체 부품에 관한 분해 조립도 및 정보는 인터넷에서도 찾아볼 수 있습니다 - www.bosch-pt.com

보수 사용 문의 팀에서는 보수의 제품 및 해당 액세서리에 관한 질문에 기꺼이 답변 드릴 것입니다.

문의나 대체 부품 주문 시에는 반드시 제품 네임 플레이트에 있는 10자리의 부품번호를 알려 주십시오.

클센터
080-955-0909

처리

기기와 액세서리 및 포장 등은 환경 친화적인 방법으로 재활용 수 있도록 분류하십시오.



전동공구를 가정용 쓰레기로 처리하지 마십시오!

ไทย

คำเตือนเพื่อความปลอดภัย

คำเตือนเพื่อความปลอดภัยทั่วไปสำหรับเครื่องมือไฟฟ้า

คำเตือน อ่านคำเตือนเพื่อความปลอดภัย คำแนะนำ ภาพประกอบ และข้อมูล

จำเพาะทั้งหมดที่จัดส่งมาพร้อมกับเครื่องมือไฟฟ้า การไม่ปฏิบัติตามคำแนะนำทั้งหมดที่ระบุไว้ด้านล่างนี้อาจทำให้ถูกไฟฟ้าดูด เกิดไฟไหม้ และ/หรือได้รับบาดเจ็บอย่างร้ายแรง

เก็บรักษาคำเตือนและคำสั่งทั้งหมดสำหรับเปิดอ่านในภายหลัง

คำว่า "เครื่องมือไฟฟ้า" ในคำเตือนหมายถึง เครื่องมือไฟฟ้าของท่านที่ทำงานด้วยพลังงานไฟฟ้าจากแหล่งจ่ายไฟหลัก (มีสายไฟฟ้า) และเครื่องมือไฟฟ้าที่ทำงานด้วยพลังงานไฟฟ้าจากแบตเตอรี่ (ไร้สาย)

ความปลอดภัยในสถานที่ทำงาน

- ▶ **รักษาสถานที่ทำงานให้สะอาดและมีไฟส่องสว่างดี** สถานที่ที่มีมืดหรืออคร้งรังนำมาซึ่งอุบัติเหตุ
- ▶ **อย่าใช้เครื่องมือไฟฟ้าทำงานในสภาพบรรยากาศที่จุดติดไฟได้ เช่น ในที่ที่มีของเหลวไวไฟ ก๊าซ หรือฝุ่น** เมื่อใช้เครื่องมือไฟฟ้าจะเกิดประกายไฟซึ่งอาจจุดฝุ่นหรือไอให้ลุกเป็นไฟได้
- ▶ **ขณะใช้เครื่องมือไฟฟ้าทำงาน ต้องกันเด็กและผู้ยืนดูให้ออกห่าง** การหันเหความสนใจอาจทำให้ท่านขาดการควบคุมเครื่องมือ

ความปลอดภัยเกี่ยวกับไฟฟ้า

- ▶ **ปลั๊กของเครื่องมือไฟฟ้าต้องเหมาะสมพอดีกับเต้าเสียบ** อย่าตัดแปลงปลั๊กไม่ว่าในลักษณะใดๆ อย่างเด็ดขาด อย่าใช้ปลั๊กหงดต่อใดๆ กับเครื่องมือไฟฟ้าที่มีสายดิน ปลั๊กที่ไม่ตัดแปลงและเต้าเสียบที่เข้ากันช่วยลดความเสี่ยงจากการถูกไฟฟ้าดูด
- ▶ **หลีกเลี่ยงอย่าให้ร่างกายสัมผัสกับพื้นผิวที่ต่อสายดินหรือลงกราวด์ไว้ เช่น ห่อ เครื่องทำความร้อน เต้า และตู้เย็น** จะเสี่ยงอันตรายจากการถูกไฟฟ้าดูดมากขึ้นหากกระแสไฟฟ้าวิ่งผ่านร่างกายของท่านลงดิน
- ▶ **อย่าให้เครื่องมือไฟฟ้าถูกฝนหรืออยู่ในสภาพเปียกชื้น** หากน้ำเข้าในเครื่องมือไฟฟ้า จะเพิ่มความเสี่ยงจากการถูกไฟฟ้าดูด
- ▶ **อย่าใช้สายไฟฟ้าในทางที่ผิด** อย่าใช้สายไฟฟ้าเพื่อยก ดึง หรือถอดปลั๊กเครื่องมือไฟฟ้า กันสายไฟฟ้าออกจากความร้อน น้ำมัน ขอบแหลมคม หรือชิ้นส่วนที่เคลื่อนที่ สายไฟฟ้าที่ชำรุดหรือพันกันยุ่งเพิ่มความเสี่ยงจากการถูกไฟฟ้าดูด
- ▶ **เมื่อใช้เครื่องมือไฟฟ้าทำงานกลางแจ้ง ให้ใช้สายไฟต่อที่เหมาะสมสำหรับงานกลางแจ้ง** การใช้สายไฟต่อที่เหมาะสมสำหรับงานกลางแจ้ง ช่วยลดอันตรายจากการถูกไฟฟ้าดูด
- ▶ **หากไม่สามารถหลีกเลี่ยงการใช้เครื่องมือไฟฟ้าทำงานในสถานที่เปียกชื้นได้ ให้ใช้สวิทซ์ตัดวงจรเมื่อเกิดการรั่วไหลของไฟฟ้าจากสายดิน (RCD)** การใช้สวิทซ์ตัดวงจรเมื่อเกิดการรั่วไหลของไฟฟ้าจากสายดินช่วยลดความเสี่ยงต่อการถูกไฟฟ้าดูด

ความปลอดภัยของบุคคล

- ▶ ห้ามต้องอยู่ในสภาพพร้อมพร้อม รมั้ดระวังในสิ่งที
ท่านกำลังทำอยู่ และมีสัด้ชณะใช้เครื่องมือไฟฟ้าทำงาน
อย่าใช้เครื่องมือไฟฟ้าขณะที่ท่านกำลังเหมือย หรืออยู่
ภายใต้การครอบงำของสุรเฑ์หรือยาเสพติด
แอลกอฮอล์ และยา เมื่อใช้เครื่องมือไฟฟ้าทำงาน
ในช่วงเวลาที่ท่านขาดความเอาใจใ้อาจทำให้บุคคลมาด
เจ็บอย่างรุนแรงได้
- ▶ ใช้อุปกรณ์ปกป้องร่างกาย สวมแว่นตาป้องกันเสมอ
อุปกรณ์ปกป้อง เช่น หมวกกันนุ้ฝน รองเท้ากันลื่น หมวก
แข็ง หรือประบกทุกันเสียดังที่ไ้ตามความเหมาะสมกับ
สภาพการทำงาน จะลดการบาดเจ็บทางร่างกาย
- ▶ ป้องกันการติดเครื่องโดยไม่ตั้งใจ ตรวจสอบให้แน่ใจ
ว่าสวิตช์อยู่ในตำแหน่งปิดก่อนเชื่อมต่อเข้ากับแหล่ง
จ่ายไฟ และ/หรือแบตเตอรี่แพค ยกหรือถือเครื่องมือ
การถือเครื่องโดยใช้นิ้วหัวที่สวิตช์ หรือเสียบปลั้ง
ไฟฟ้าขณะสวิตช์เปิดอยู่ อาจนำไปสู่อุบัติเหตุที่ร้ายแรงได้
- ▶ นำเครื่องมือปรับแต่งหรือประแจปากคายนอกก่อนเปิด
สวิตช์เครื่องมือไฟฟ้า เครื่องมือหรือประแจปาก
คายนที่วางอยู่กั้บส่วนของเครื่องที่กั้ล้งหมุนจะทำให้บุคคลม
บาดเจ็บได้
- ▶ อย่าเอือมไกลเกินไป ตั้งท้ายีนที่มีคนงและวางน้ำหนักใ้
สมดุลตลอดเวลา ในลักษณะนี้ท่านสามารถควบคุมเครื่อง
มือไฟฟ้าในสถานการณ์ที่ไม่คาดคิดได้ดีกว่า
- ▶ แต่งกายอย่างเหมาะสม อย่าใส่เสื้อผ้าหลวมหรือสวม
เครื่องประดับ เอามและเสื้อผ้าออกห่างจากชิ้นส่วนที่
เคลื่อนที่ เสื้อผ้าหลวม เครื่องประดับ และผม
ยาวอาจเข้าไปติดในชิ้นส่วนที่เคลื่อนที่
- ▶ หากเครื่องมือไฟฟ้ามีข้อเชื่อมต่อกับเครื่องดูดฝุ่นหรือ
เครื่องเก็บผง ให้ตรวจสอบให้แน่ใจว่าได้เชื่อมต่อและ
ใช้งานอย่างถูกต้อง การใช้อุปกรณ์ดูด
ฝุ่นช่วยลดอันตรายที่เกิดจากฝุ่นได้
- ▶ เมื่อใช้งานเครื่องมือยครั้งจะเกิดความคุ้นเคย อย่าให้
ความคุ้นเคยทำให้ท่านเกิดความชะล่าใจและละเลยกฎ
เกณฑ์ด้านความปลอดภัยในการใช้งานเครื่อง การ
ทำงานอย่างไม่มีระมัดระวังอาจทำให้เกิดการบาดเจ็บ
อย่างร้ายแรงภายในเสี้ยววินาที

การใช้และการดูแลรักษาเครื่องมือไฟฟ้า

- ▶ อย่างฝืนกำลังเครื่องมือไฟฟ้า ใช้เครื่องมือไฟฟ้าที่ถูก
ต้องตรงตามลักษณะงานของท่าน เครื่องมือไฟฟ้าที่ถูก
ต้องจะทำงานได้ดี
กว่าและปลอดภัยกว่าในระดับสมรรถภาพที่ออกแบบไว้
- ▶ อย่าใช้เครื่องมือไฟฟ้าถ้าสวิตช์ไม่สามารถเปิดปิดได้
เครื่องมือไฟฟ้าที่ไม่สามารถควบคุมการเปิดปิดด้วยสวิตช์

ทซ์ได้ เป็นเครื่อง

มือไฟฟ้าที่ไม่ปลอดภัยและต้องส่งซ่อมแซม

- ▶ ก่อนปรับแต่งเครื่อง เปลี่ยนอุปกรณ์ประกอบ หรือเก็บ
เครื่องเข้าที่ ต้องถอดปลั้กออกจากแหล่งจ่ายไฟ และ/
หรือถอดแบตเตอรี่แพคออกจากเครื่องมือไฟฟ้าหาก
ถอดออกได้
มาตรการป้องกันเพื่อความปลอดภัยนี้ช่วยลดความ
เสี่ยงจากการติดเครื่องโดยไม่ตั้งใจ
- ▶ เมื่อเลิกใช้งานเครื่องมือไฟฟ้า ให้เก็บเครื่องไว้ในที่ที่
เด็กหยิบไม่ถึง และไมอนุญาตให้บุคคลที่ไม่คุ้นเคยกับ
เครื่องหรือบุคคลที่ไม่ได้อ่านคำแนะนำเหล่านี้ใช้เครื่อง
เครื่องมือไฟฟ้าเป็นข้อนอันตรายหากตกอยู่ในมือของผู้
ใช้ที่ไม่ได้รับการฝึกฝน
- ▶ บำรุงรักษาเครื่องมือไฟฟ้าและอุปกรณ์ประกอบ ตรวจสอบ
ชิ้นส่วนที่เคลื่อนที่ว่ามีางไม่ตรงแนวหรือติดขัดหรือ
ไม่ ตรวจสอบการแตกหักของชิ้นส่วนและสภาพอื่นใดที่
อาจมีผลต่อการทำงานของเครื่องมือไฟฟ้า หากชำรุด
ต้องส่งเครื่องมือไฟฟ้าไปซ่อมแซมก่อนใช้งาน
อุบัติเหตุหลายอย่างเกิดขึ้นเนื่องจากดูแลรักษาเครื่องไม่
ดีพอ
- ▶ รักษาเครื่องมือตัดให้คมและสะอาด
หากบำรุงรักษาเครื่องมือที่มีขอบตัดแหลมคมอย่างถูกต้อง
จะสามารถตัดได้ลื่นไม่ติดขัดและควบคุมได้ง่ายกว่า
- ▶ ใช้เครื่องมือไฟฟ้า อุปกรณ์ประกอบ เครื่องมือ และอุปกร
ณ์อื่นๆ ตรงตามคำแนะนำเหล่านี้ โดยคำนึงถึง
เงื่อนไขการทำงานและงานที่จะทำ การใช้เครื่อง
มือไฟฟ้าทำงานที่ต่างไปจากวัตถุประสงค์การ
ใช้งานของเครื่อง อาจนำไปสู่สถานการณ์ที่เป็นอันตรายได้
- ▶ ดูแลตามจับและพื้นผิวจับให้แห้ง สะอาด และปราศจาก
คราบน้ำมันและจาระบี ตามจับและพื้นผิว
จับที่ลื่นทำให้หยิบจับได้ไม่ปลอดภัย
และไม่สามารถควบคุมเครื่องมือในสถานการณ์ที่ไม่คาดคิด

การบริการ

- ▶ ส่งเครื่องมือไฟฟ้าของท่านเข้ารับบริการจากช่าง
ซ่อมที่มีคุณสมบัติเหมาะสม โดยใช้อะไหล่ที่เหมือน
กันเท่านั้น ในลักษณะนี้ท่านจะแน่ใจได้ว่าเครื่อง
มือไฟฟ้าอยู่ในสภาพที่ปลอดภัย

คำเตือนเพื่อความปลอดภัยสำหรับเสียดล

- ▶ เมื่อทำงานในบริเวณที่อุปกรณ์ตัดอาจสัมผัสสายไฟฟ้าที่
ซ่อนอยู่หรือสายไฟฟ้าของตัวเอง ต้องจับเครื่อง
มือไฟฟ้าตรงพื้นผิวจับที่หุ้มฉนวน หากอุปกรณ์ตัดสัมผัส
สายที่ “มีกระแสไฟฟ้า” ไหลผ่าน จะทำให้ชิ้นส่วนโลหะที่
ไม่ได้หุ้มฉนวนของเครื่องมือไฟฟ้าเกิด “มีกระแสไฟฟ้า”
ด้วย และส่งผลให้ผู้ใช้งานเครื่องถูกไฟฟ้าดูดได้

- ▶ **ใช้เครื่องมือหรือวิธีอื่นที่ได้ผลเพื่อยึดและหมุนชิ้นงานกับแท่นที่มั่นคง** การจับชิ้นงานด้วยมือหรือยืนไว้กับร่างกายจะไม่มั่นคง และอาจทำให้สูญเสียการควบคุมได้
- ▶ **เอามือออกห่างจากบริเวณแนวเลื่อย อย่าเอื้อมมือเข้าใต้ชิ้นงาน** การสัมผัสกับใบเลื่อยจะทำให้บาดเจ็บได้
- ▶ **จับเครื่องมือไฟฟ้าเข้าหาชิ้นงานเมื่อเครื่องเปิดสวิตช์อยู่เท่านั้น** มิฉะนั้นอาจได้รับอันตรายจากการตีกลับหากเครื่องมือตัดติดขัดอยู่ในชิ้นงาน
- ▶ **ตรวจสอบให้แน่ใจว่าขณะเลื่อยได้วางแผ่นฐานไว้อย่างมั่นคง** ใบเลื่อยที่ติดขัดอาจแตกหัก หรือทำให้เกิดการตีกลับได้
- ▶ **เมื่อเสร็จสิ้นการทำงาน ให้ปิดสวิตช์เครื่องมือไฟฟ้าและดึงใบเลื่อยออกจากร่องตัดเมื่อใบเลื่อยหยุดนิ่งอยู่กับที่แล้วเท่านั้น** ในลักษณะนี้ท่านสามารถหลีกเลี่ยงการตีกลับ และวางเครื่องลงได้อย่างปลอดภัย
- ▶ **รอให้เครื่องมือไฟฟ้าหยุดสนิทก่อนวางเครื่องลงบนพื้น** เครื่องมือที่ปล่อยอาจติดขัดและทำให้สูญเสียการควบคุมเครื่องมือไฟฟ้า
- ▶ **ใช้เฉพาะใบเลื่อยที่ไม่ชำรุดและมีสภาพที่สมบูรณ์เท่านั้น** ใบเลื่อยที่หักหรือบิดงอสามารถแตกหัก ส่งผลเชิงลบต่อการตัด หรือทำให้เกิดการตีกลับได้
- ▶ **หลังปิดสวิตช์ อย่าเบรกใบเลื่อยให้หยุดวิ่งโดยการกดลงด้านข้าง** ใบเลื่อยอาจชำรุด แตกหัก หรือทำให้เกิดการตีกลับได้
- ▶ **ใช้เครื่องตรวจจับที่เหมาะสมเพื่อตรวจสอบหาสายไฟฟ้าหรือท่อสาธารณูปโภคที่อาจซ่อนอยู่ในบริเวณทำงานหรือติดตั้งบริษัทสาธารณูปโภคในพื้นที่เพื่อขอความช่วยเหลือ** การสัมผัสกับสายไฟฟ้าอาจทำให้เกิดไฟไหม้หรือถูกไฟฟ้าดูด การทำไฟทอกแซเสียหายอาจทำให้เกิดระเบิด การเจาะเขาในท่อน้ำทำให้ทรัพย์สินเสียหาย หรืออาจเป็นเหตุให้ถูกไฟฟ้าดูดได้

รายละเอียดผลิตภัณฑ์และข้อมูลจำเพาะ



อ่านคำเตือนเพื่อความปลอดภัยและคำแนะนำทั้งหมด การไม่ปฏิบัติตามคำเตือนและคำสั่งอาจเป็นสาเหตุให้ถูกไฟฟ้าดูด เกิดไฟไหม้และ/หรือได้รับบาดเจ็บอย่างร้ายแรง
กรุณาดูภาพประกอบในส่วนหน้าของคู่มือการใช้งาน

ประโยชน์การใช้งานของเครื่อง

เครื่องนี้ใช้สำหรับตัดไม้ พลาสติก โลหะ แผ่นเซรามิก และยาง เพื่อแยกส่วนออกจากกันและเพื่อตัดออกโดยต้องวางเครื่องอย่างมั่นคงลงบนชิ้นงาน เครื่อง

นี้เหมาะสำหรับตัดแนวตรงและตัดโค้ง อ่านและปฏิบัติตามข้อแนะนำเกี่ยวกับใบเลื่อย

ส่วนประกอบผลิตภัณฑ์

ลำดับเลขของส่วนประกอบผลิตภัณฑ์ข้างถึงส่วนประกอบของเครื่องที่แสดงในหน้าภาพประกอบ

- (1) ฝาครอบหมุน SDS การปลดล็อคใบเลื่อย
- (2) ปุ่มล็อคของสวิตช์เปิด-ปิด
- (3) สวิตช์เปิด-ปิด
- (4) ปุ่มเลือกอัตราขยายชักล่างหน้า
- (5) แผ่นฐาน
- (6) สวิตช์ เครื่องเบ้าซี่เลื่อย
- (7) คันโยกสำหรับปรับการเตะ
- (8) ตัวจับใบเลื่อย
- (9) หัวจับใบเลื่อย
- (10) ใบเลื่อย^{A)}
- (11) ฝาครอบ
- (12) ช่องนำแผ่นนำเลื่อยแบบขนาน
- (13) กันชน
- (14) ด้ามจับ (พื้นผิวจับหุ้มฉนวน)
- (15) แผ่นป้องกันการฉีกที่ผิววัสดุ^{A)}
- (16) สกรูล็อคแผ่นนำเลื่อยแบบขนาน^{A)}
- (17) แผ่นนำเลื่อยแบบขนานพร้อมอุปกรณ์ตัดวงกลม^{A)}
- (18) ตัวหมายศูนย์กลางของอุปกรณ์ตัดวงกลม^{A)}

A) อุปกรณ์ประกอบที่แสดงภาพหรืออธิบายไม่รวมอยู่ในการจัดส่งมาตรฐาน
กรุณาดูอุปกรณ์ประกอบทั้งหมดในรายการแสดงอุปกรณ์ประกอบของเรา

ข้อมูลทางเทคนิค

เลื่อยฉลุ	GST 25 M	
หมายเลขสินค้า		3 601 E16 ...
การควบคุมอัตราขยายชัก		●
ระบบอิเล็กทรอนิกส์ที่		●
กำลังไฟฟ้าที่ติดตั้งเข้า	วัตต์	670
อัตราขยายชักเดินตัวเปล่า n_0	นาที ⁻¹	500–2600
ระยะช่วงชัก	มม.	24
ความลึกการตัด สูงสุด		

เลื่อยจล		GST 25 M
- ในไม้	มม.	80
- ในอะลูมิเนียม	มม.	25
- ในเหล็กกล้า (ไม่เจือ)	มม.	15
น้ำหนักตามระเบียบการ EPTA-Procedure 01:2014	กก.	2.7
ระดับความปลอดภัย		 /

ค่าที่ให้นี้ใช้ได้กับแรงดันไฟฟ้าอนินอล [U] 230 โวลต์ค่าเหล่านี้ อาจเปลี่ยนแปลงไปสำหรับแรงดันไฟฟ้าที่แตกต่างกัน และโมเดลที่ผลิตสำหรับเฉพาะประเทศ

การติดตั้ง

▶ ดึงปลั๊กไฟออกจากเต้าเสียบก่อนปรับแต่งเครื่อง

การใส่/การเปลี่ยนใบเลื่อย

- ▶ เมื่อติดตั้งหรือเปลี่ยนเครื่องมือ ต้องสวมถุงมือป้องกัน เครื่องมือมีความคมและอาจร้อนขึ้นเมื่อใช้งานเป็นเวลานาน

การเลือกใบเลื่อย

กรุณาดูภาพรวมของใบเลื่อยที่แนะนำที่ปรากฏอยู่ตอนท้ายของคู่มือเล่มนี้ ให้ใช้เฉพาะใบเลื่อยที่มีก้านรูเดียว (T shank) เท่านั้น ใบเลื่อยควรมีขนาดยาวกว่าความหนา การตัดที่ต้องการเพียงเล็กน้อยเท่าที่จำเป็น ใช้ใบเลื่อยบางเมื่อตัดโค้งแคบ

การใส่/การถอดใบเลื่อย (ดูภาพประกอบ A)

- ▶ ทำความสะอาดก้านของใบเลื่อยก่อนใส่ ก้านที่สกปรกไม่สามารถยึดได้อย่างแน่นหนา

- 1 ดึงฝาครอบหมุน SDS (1) ขึ้นด้านบน
- 2 หากต้องการปลดล็อกให้หมุนฝาครอบหมุน SDS (1) ทวนเข็มนาฬิกาประมาณ 3 รอบ
- 3 ใส่ใบเลื่อย (10) ขวางกับทิศทางการตัดเข้าในตัวจับใบเลื่อย (8)
- 4 หมุนใบเลื่อย (10) โดยให้ฟันเลื่อยหันไปยังทิศทางการตัด ตรวจสอบให้แน่ใจว่าส่วนหลังใบเลื่อยอยู่ในร่องของตัวจับใบเลื่อย (9)
- 5 หมุนฝาครอบหมุน SDS (1) ตามเข็มนาฬิกาจนพบเขาที่
- 6 หมุนฝาครอบหมุน SDS (1) ตามเข็มนาฬิกาต่อไปจนถึงตำแหน่งเริ่มต้น เลื่อนฝาครอบหมุน SDS ลงด้านล่างเพื่อล็อก

- ▶ ตรวจสอบให้ใบเลื่อยเข้าที่อย่างมั่นคง ใบเลื่อยที่ใส่ไว้หลวมๆ อาจหล่นออกมาและทำให้บาดเจ็บได้ เมื่อต้องการถอดใบเลื่อยออก ให้ทำตามลำดับข้อหลัง

แผ่นป้องกันการฉีกที่ผิววัสดุ (ดูภาพประกอบ B)

แผ่นป้องกันการฉีกที่ผิววัสดุ (15) (อุปกรณ์ประกอบ) สามารถป้องกันไม่ให้ผิววัสดุลู่เป็นฝอยขณะเลื่อยไม้ แผ่นป้องกันการฉีกที่ผิววัสดุสามารถใช้กับใบเลื่อยบางประเภทเท่านั้น

กดแผ่นป้องกันการฉีกที่ผิววัสดุ (15) จากด้านล่างเข้าไปในแผ่นฐาน (5)

การดูดฝุ่น/ขี้เลื่อย

ฝุ่นที่ได้จากวัสดุ เช่น เคลือบผิวที่มีสารตะกั่ว ไม้ยางประเภทแร้ธาตุ และโลหะ อาจเป็นอันตรายต่อสุขภาพ การสัมผัสหรือการหายใจเอาฝุ่นเข้าไปอาจทำให้เกิดปฏิกิริยาแพ้ฝุ่น และ/หรือนำมาซึ่งโรคติดเชื้อระบบหายใจแก่ผู้ใช้เครื่องหรือผู้ที่ยืนอยู่ใกล้เคียง

ฝุ่นบางประเภท เช่น ฝุ่นไม้โอ๊ก หรือไม้บีช นับเป็นสารที่ทำให้เกิดมะเร็ง โดยเฉพาะอย่างยิ่งเมื่อผสมกับสารเติมแต่งเพื่อบำบัดไม้ (โครเมต ผลิตภัณฑ์รักษาเนื้อไม้) สำหรับวัสดุที่มีแอลเบทอสตองให้ผู้ใช้ชาวชายทำงานเท่านั้น

- จัดสถานที่ทำงานให้มีการระบายอากาศที่ดี
- ขอแนะนำให้สวมหน้ากากป้องกันการติดเชื้อที่มีระดับ-ใส่กรอง P2

ปฏิบัติตามกฎข้อบังคับสำคัญอื่น ๆ ที่เกี่ยวกับวัสดุชิ้นงานที่ยังคงใช้ในประเทศของท่าน

- ▶ ป้องกันการสะสมของฝุ่นในสถานที่ทำงาน ฝุ่นสามารถถูกใหม่อย่างง่ายดาย

ฝาครอบ (ดูภาพประกอบ C)

ขี้เลื่อยจากโลหะที่มีขอบคมและร้อนทำให้เกิดการบาดเจ็บได้ ดังนั้นให้ติดตั้งฝาครอบ (11) เมื่อทำงานในโลหะหรืออะลูมิเนียม

สวมฝาครอบ (11) เข้าบนเครื่องมือไฟฟ้าในลักษณะให้ตัวยึดชนเข้าบนกันชน (13)

ถอดฝาครอบ (11) ออกเมื่อทำงานในไม้ เมื่อต้องการถอดให้ดึงฝาครอบไปข้างหน้าออกจากกันชน (13)

การปฏิบัติงาน

รูปแบบการทำงาน

- ▶ ดึงปลั๊กไฟออกจากเต้าเสียบก่อนปรับแต่งเครื่อง

การเตะ

การเตะช่วยให้สามารถปรับความเร็วการตัด ประสิทธิภาพการตัด และรูปแบบการตัดให้เหมาะสมกับวัสดุชิ้นงาน เปิดการเตะ ต. ย. เช่น สำหรับการเลื่อยวัสดุอ่อนนุ่มและเมื่อเลื่อยไม่ในทิศทางเดียวกัน เมื่อต้องการเปิดการเตะให้เลื่อนคันโยก (7) ไปยังตำแหน่ง "I" เลื่อนโดแม่ในระหว่างดำเนินการเปิดการเตะเพื่อให้ได้ขอบตัดที่ประณีตและคมชัด รวมถึงเมื่อทำงานกับวัสดุชิ้นบาง (ต. ย. เช่น แผ่นโลหะ) เมื่อต้องการปิดการเตะให้เลื่อนคันโยก (7) ไปยังตำแหน่ง "0"

เครื่องเป่าซีล

กระแสลมจากเครื่องเป่าซีลจะทำให้ตรงรอยตัดปราศจากผงฝุ่นและซีลเลื่อย

เปิดสวิตช์เครื่องเป่าซีลเมื่อเลื่อยไม้ พลาสติก และวัสดุอื่นที่คล้ายคลึงกันที่มีอัตราการขจัดสูง ให้กดสวิตช์ (6) ไปยังตำแหน่ง "I"

ปิดเครื่องเป่าซีลเมื่อทำงานในโลหะ เมื่อต้องการปิดให้กดสวิตช์ (6) ไปยังตำแหน่ง "0"

การเริ่มต้นปฏิบัติงาน**▶ ให้สังเกตแรงดันไฟฟ้า! แรง**

ดันไฟฟ้าจากแหล่งจ่ายไฟฟ้าต้องมีค่าตรงกับค่าแรงดันไฟฟ้าที่ระบุไว้บนแผ่นป้ายกำกับเครื่อง เครื่องมือไฟฟ้าที่มีเครื่องหมาย 230 โวลต์ สามารถใช้งานได้กับ 220 โวลต์ ได้ด้วย

การเปิด-ปิดเครื่อง**▶ ตรวจสอบให้แน่ใจว่าท่านสามารถใช้งานสวิตช์เปิด-ปิดได้โดยไม่ต้องปล่อยตามจับ**

เปิดสวิตช์ เครื่องมือไฟฟ้าโดยกดสวิตช์เปิด-ปิด (3)

ล็อคสวิตช์เปิด-ปิด (3) โดยกดสวิตช์ค้างไว้และดันปุ่มล็อค (2) ไปทางซ้ายหรือทางขวา

ปิดสวิตช์ เครื่องมือไฟฟ้าโดยปล่อยนิ้วจากสวิตช์เปิด-ปิด (3)

หากสวิตช์เปิด-ปิด (3) ถูกล็อคไว้ ให้กดสวิตช์ก่อน แล้วจึงปล่อยนิ้ว

ระบบอิเล็กทรอนิกส์ที่

ระบบควบคุมอิเล็กทรอนิกส์ที่จะรักษาอัตราเร็วขยับขณะเดินเครื่องตัวเปล่าและขณะใช้งานให้มีค่าเกือบคงที่ และทำให้ได้ประสิทธิภาพการทำงานที่สม่ำเสมอ

การควบคุม/การตั้งความเร็วขยับชักล่งหน้า

ท่านสามารถควบคุมความเร็วขยับชักของเครื่องมือไฟฟ้าที่เปิดสวิตช์ไว้ได้อย่างต่อเนื่อง โดยเพิ่มหรือลดแรงกดบนสวิตช์เปิด-ปิด (3)

เมื่อกดบนสวิตช์เปิด-ปิด (3) เบาๆ จะได้ความเร็วขยับชักต่ำ ถ้ากดแรงขึ้น ความเร็วขยับชักก็จะเพิ่มขึ้นด้วย

หากสวิตช์เปิด-ปิด (3) ถูกล็อคไว้ จะไม่สามารถลดความเร็วขยับชักได้

สามารถตั้งความเร็วขยับชักล่งหน้าด้วยปุ่มเลือกความเร็วขยับชักล่งหน้า (4) และเปลี่ยนค่าได้ขณะเครื่องกำลังเดินอยู่

เกณฑ์จ้งหะขยับชักที่ต้งใช้ซึ้นอยู่กับประเภทวัสดุชิ้นงานและเงื่อนไขการทำงาน การทดลองภาคปฏิบัติจะช่วยให้ได้เกณฑ์จ้งหะที่ตีที่สุด

ขอแนะนำให้ลดอัตราเร็วขยับชักลงขณะใบเลื่อยขบเข้าในวัสดุชิ้นงาน และเมื่อเลื่อยพลาสติกและอะลูมิเนียม

เมื่อทำงานที่อัตราเร็วขยับชักต่ำเป็นเวลานาน เครื่องอาจร้อนขึ้นมาก ให้ถอดใบเลื่อยออก และทำให้เครื่องมือไฟฟ้าเย็นลงโดยปล่อยให้เครื่องเดินด้วยความเร็วขยับชักสูงสักระยะประมาณ 3 นาที

ข้อแนะนำในการทำงาน

- ▶ **ดึงปลั๊กไฟออกจากเต้าเสียบก่อนปรับแต่งเครื่อง**
- ▶ **หากใบเลื่อยติดขัด ให้ปิดสวิตช์เครื่องทันที**
- ▶ **เมื่อทำงานกับชิ้นงานขนาดเล็กหรือบาง ให้ใช้พื้นรองรับที่แข็งแรงเสมอ**

ก่อนเลื่อยในไม้ ไม้อัด วัสดุก่อสร้าง ฯลฯ ให้ตรวจหาสิ่งแปลกปลอม เช่น ตะปู สกรู หรือสิ่งคล้ายคลึงในวัสดุเหล่านี้ และหากจำเป็นให้ถอนสิ่งแปลกปลอมนั้นออกไป

การจ้งตัด (ดูภาพประกอบ D)**▶ ท่านสามารถจ้งตัดในวัสดุอ่อนนุ่ม เช่น ไม้เนื้ออ่อน อีปซัมบอร์ด หรือวัสดุที่คล้ายคลึงกันเท่านั้น!**

สำหรับการจ้งตัดให้ใช้เฉพาะใบเลื่อยสั้นเท่านั้น

วางเครื่องมือไฟฟ้าโดยให้ขอบหน้าของแผ่นฐาน (5) จดลงบนชิ้นงาน แต่ไม่ให้ใบเลื่อย (10) และชิ้นงาน และเปิดสวิตช์สำหรับเครื่องมือไฟฟ้าที่มีการควบคุมความเร็วขยับชัก ให้ตั้งความเร็วขยับชักสูงสุด จับเครื่องมือไฟฟ้าเข้าหาชิ้นงานอย่างมั่นคงและจ้งใบเลื่อยเข้าในชิ้นงานอย่างช้าๆ เมื่อแผ่นฐาน (5) วางเต็มทีบนพื้นผิววัสดุแล้วให้เลื่อยตามเส้นตัดที่ต้องการต่อไป

แผ่นนำเลื่อยแบบขนานพร้อมอุปกรณ์ตัดวงกลม (อุปกรณ์ประกอบ)

สำหรับการตัดโดยใช้แผ่นนำเลื่อยแบบขนานพร้อมอุปกรณ์ตัดวงกลม (17) (อุปกรณ์ประกอบ) ความหนาสูงสุดของวัสดุชิ้นงานคือ 30 มม.

การตัดแบบขนาน (ดูภาพประกอบ E): คลายสกรูล็อค (16) ออกและเลื่อนมาตรงส่วนของแผ่นนำเลื่อยแบบขนานเข้าในช่องนำ (12) ในแผ่นฐาน ตั้งความกว้างการตัดที่ต้องการเป็นค่ามาตรฐานส่วนบนของด้านในของแผ่นฐาน ชิ้นสกรูล็อค (16) เข้าให้แน่น

การตัดวงกลม (ดูภาพประกอบ F): เจาะรูใกล้กับเส้นตัดภายในวงกลมที่จะเลื่อย โดยรูต้องใหญ่พอที่จะใส่ใบเลื่อยแก๊ซที่เราจะด้วยเราเตอร์หรือตะไบเพื่อให้สามารถวางใบเลื่อยชิดกับเส้นตัดได้

ปรับตำแหน่งสกรูล็อค (16) ที่อีกด้านหนึ่งของแผ่นนำเลื่อยแบบขนาน เลื่อนมาตามราวลของแผ่นนำเลื่อยแบบขนานเข้าในช่องนำ (12) ในแผ่นฐาน เจาะรูเข้าในชิ้นงานโดยให้รูอยู่ตรงกลางส่วนที่จะเลื่อยออก ใส่ตัวหมยศูนย์กลาง (18) ผ่านช่องเปิดด้านในของแผ่นนำเลื่อยแบบขนานและเข้าในรูที่เจาะไว้ ตั้งรัศมีเป็นค่ามาตราส่วนที่ขอบด้านในของแผ่นฐาน ชิ้นสกรูล็อค (16) เข้าให้แน่น

สารหล่อเย็น/น้ำมันหล่อลื่น

เมื่อเลื่อยโลหะ ให้ใช้โลมสารหล่อเย็น/น้ำมันหล่อลื่นตามรอยตัดเนื่องจากวัสดุร้อนขึ้น

การบำรุงรักษาและการบริการ

การบำรุงรักษาและการทำความสะอาด

- ▶ **ดึงปลั๊กไฟออกจากเต้าเสียบก่อนปรับแต่งเครื่อง**
- ▶ **เพื่อให้ทำงานได้อย่างถูกต้องและปลอดภัย ต้องรักษาเครื่องและช่องระบายอากาศให้สะอาดอยู่เสมอ**

หากจำเป็นต้องเปลี่ยนสายไฟฟ้า ต้องส่งเครื่องให้ Bosch หรือศูนย์บริการหลังการขายที่ได้รับมอบหมายสำหรับเครื่องมือไฟฟ้า Bosch เปลี่ยนให้ ทั้งนี้เพื่อหลีกเลี่ยงอันตราย

ทำความสะอาดที่จับใบเลื่อยเป็นประจำ

สำหรับการทำความสะอาด ให้ถอดใบเลื่อยออกจากตัวเครื่อง และจับเครื่องเคาะบนพื้นราบเบาๆ

หากเครื่องมือไฟฟ้าสกปรกมาก เครื่องอาจทำงานผิดปกติได้ ดังนั้นอย่าเลื่อยวัสดุที่ให้ฝุ่นมากจากทางด้านล่างหรือเหนือศีรษะ

- ▶ **หากใช้เครื่องทำงานหนัก ให้ใช้อุปกรณ์ดูดฝุ่นนอกเท่าที่จะทำได้เสมอ เป่าช่องระบายอากาศเป็นประจำและติดตั้งเครื่องตัดไฟรั่ว (RCD) เมื่อทำงานกับโลหะ**

ฝุ่นซึ่งมีคุณสมบัตินำความร้อนและกระแสไฟฟ้าอาจสะสมอยู่ข้างในเครื่องมือไฟฟ้า

ฉนวนป้องกันทั้งหมดของเครื่องมือไฟฟ้าอาจได้รับผลเสีย

หล่อลื่นหัวจับใบเลื่อย (9) เป็นครั้งคราวโดยการหยอดน้ำมัน ตรวจสอบหัวจับใบเลื่อย (9) เป็นประจำ หากสึกหรอ ต้องส่งไปยังศูนย์บริการหลังการขาย Bosch ที่ได้รับมอบหมายเพื่อทำการเปลี่ยนให้

การบริการหลังการขายและการให้คำปรึกษาการใช้งาน

ศูนย์บริการหลังการขายของเรายินดีตอบคำถามของท่านที่เกี่ยวกับการบำรุงรักษาและการซ่อมแซมผลิตภัณฑ์รวมทั้งเรื่องอะไหล่ ภาพเขียนแบบการประกอบและข้อมูลเกี่ยวกับอะไหล่ กรุณาดูใน: **www.bosch-pt.com**

ทีมงานที่ปรึกษาของ บอช ยินดีให้ข้อมูลเกี่ยวกับผลิตภัณฑ์ของเราและอุปกรณ์ประกอบต่างๆ

เมื่อต้องการสอบถามและสั่งซื้ออะไหล่ กรุณาแจ้งหมายเลขสินค้า 10 หลักบนแผ่นป้ายรุ่นของผลิตภัณฑ์ทุกครั้ง

ไทย

ไทย บริษัท โรเบิร์ต บอช จำกัด

อพวยไอ เซ็นเตอร์ อาคาร 1 ชั้น 5

เลขที่ 2525 ถนนพระราม 4

แขวงคลองเตย เขตคลองเตย กรุงเทพฯ 10110

โทร: +66 2012 8888

แฟกซ์: +66 2064 5800

www.bosch.co.th

ศูนย์บริการซ่อมและฝึกอบรม บอช

อาคาร ลาซาลทาวเวอร์ ชั้น G ห้องเลขที่ 2

บ้านเลขที่ 10/11 หมู่ 16

ถนนศรีนครินทร์ ตำบลบางแก้ว อำเภอบางพลี

จังหวัดสมุทรปราการ 10540

ประเทศไทย

โทรศัพท์ 02 7587555

โทรสาร 02 7587525

การกำจัดขยะ

เครื่องมือไฟฟ้า อุปกรณ์ประกอบ และหีบห่อ ต้องนำไปแยกประเภทวัสดุเพื่อการรีไซเคิลที่เป็นมิตรต่อสิ่งแวดล้อม



อย่าทิ้งเครื่องมือไฟฟ้าลงในขยะครัวเรือน!

Bahasa Indonesia

Petunjuk Keselamatan

Petunjuk keselamatan umum untuk perkakas listrik

⚠ PERINGATAN Baca semua peringatan, petunjuk, ilustrasi, dan spesifikasi keselamatan yang diberikan bersama perkakas listrik ini. Kesalahan dalam menjalankan petunjuk di bawah ini

dapat mengakibatkan sengatan listrik, kebakaran, dan/atau cedera serius.

Simpanlah semua peringatan dan petunjuk untuk penggunaan di masa mendatang.

Istilah "perkakas listrik" dalam peringatan mengacu pada perkakas listrik yang dioperasikan dengan listrik (menggunakan kabel) atau perkakas listrik yang dioperasikan dengan baterai (tanpa kabel).

Keamanan tempat kerja

- ▶ **Jaga kebersihan dan pencahayaan area kerja.** Area yang berantakan atau gelap dapat memicu kecelakaan.
- ▶ **Jangan mengoperasikan perkakas listrik di lingkungan yang dapat memicu ledakan, seperti adanya cairan, gas, atau debu yang mudah terbakar.** Perkakas listrik dapat memancarkan bunga api yang kemudian mengakibatkan debu atau uap terbakar.
- ▶ **Jauhkan dari jangkauan anak-anak dan pengamat saat mengoperasikan perkakas listrik.** Gangguan dapat menyebabkan hilangnya kendali.

Keamanan listrik

- ▶ **Steker perkakas listrik harus sesuai dengan stopkontak. Jangan pernah memodifikasi steker. Jangan menggunakan steker adaptor bersama dengan perkakas listrik yang terhubung dengan sistem grounding.** Steker yang tidak dimodifikasi dan stopkontak yang cocok akan mengurangi risiko sengatan listrik.
- ▶ **Hindari kontak badan dengan permukaan yang terhubung dengan sistem grounding, seperti pipa, radiator, kompor, dan lemari es.** Terdapat peningkatan risiko terjadinya sengatan listrik jika badan Anda terhubung dengan sistem grounding.
- ▶ **Perkakas listrik tidak boleh terpapar hujan atau basah.** Air yang masuk ke dalam perkakas listrik menambah risiko terjadinya sengatan listrik.
- ▶ **Jangan menyalahgunakan kabel. Jangan gunakan kabel untuk membawa, menarik, atau melepas steker perkakas listrik. Jauhkan kabel dari panas, minyak, tepi yang tajam, atau komponen yang bergerak.** Kabel listrik yang rusak atau tersangkut menambah risiko terjadinya sengatan listrik.
- ▶ **Saat mengoperasikan perkakas listrik di luar ruangan, gunakan kabel ekstensi yang sesuai untuk penggunaan di luar ruangan.** Penggunaan kabel yang cocok untuk pemakaian di luar ruangan mengurangi risiko terjadinya sengatan listrik.
- ▶ **Jika perkakas listrik memang harus dioperasikan di tempat yang lembap, gunakan pemutus arus listrik residu (RCD).** Penggunaan RCD akan mengurangi risiko terjadinya sengatan listrik.

Keselamatan personel

- ▶ **Tetap waspada, perhatikan aktivitas yang sedang dikerjakan dan gunakan akal sehat saat mengoperasikan perkakas listrik. Jangan gunakan perkakas listrik saat mengalami kelelahan atau di**

bawah pengaruh narkoba, alkohol, atau obat-obatan.

Jika perkakas listrik dioperasikan dengan daya konsentrasi yang rendah, hal tersebut dapat menyebabkan cedera serius.

- ▶ **Gunakan peralatan pelindung diri. Selalu kenakan pelindung mata.** Penggunaan perlengkapan pelindung seperti penutup telinga, helm, sepatu anti licin, dan masker debu akan mengurangi cedera.
- ▶ **Hindari start yang tidak disengaja. Pastikan switch berada di posisi off sebelum perkakas listrik dihubungkan ke sumber daya listrik dan/atau baterai, diangkat, atau dibawa.** Membawa perkakas listrik dengan jari menempel pada tombol atau perkakas listrik dalam keadaan hidup dapat memicu kecelakaan.
- ▶ **Singkirkan kunci penyetel atau kunci pas sebelum menghidupkan perkakas listrik.** Perkakas atau kunci pas yang masih menempel pada komponen perkakas listrik yang berputar dapat menyebabkan cedera.
- ▶ **Jangan melampaui batas. Berdirilah secara mantap dan selalu jaga keseimbangan.** Hal ini akan memberikan kontrol yang lebih baik terhadap perkakas listrik pada situasi yang tak terduga.
- ▶ **Kenakan pakaian dengan wajar. Jangan mengenakan perhiasan atau pakaian yang longgar. Jauhkan rambut dan pakaian dari komponen yang bergerak.** Pakaian yang longgar, rambut panjang, atau perhiasan dapat tersangkut dalam komponen yang bergerak.
- ▶ **Jika disediakan perangkat untuk sambungan pengisapan debu dan alat pengumpulan, pastikan perangkat tersebut terhubung dan digunakan dengan benar.** Penggunaan alat pengumpulan dapat mengurangi bahaya yang disebabkan oleh debu.
- ▶ **Jangan berpuas diri dan mengabaikan prinsip keselamatan karena terbiasa mengoperasikan perkakas.** Tindakan yang kurang hati-hati dapat mengakibatkan cedera serius dalam waktu sepersekian detik.

Penggunaan dan pemeliharaan perkakas listrik

- ▶ **Jangan memaksakan perkakas listrik. Gunakan perkakas listrik yang sesuai untuk pekerjaan yang dilakukan.** Perkakas listrik yang sesuai akan bekerja dengan lebih baik dan aman sesuai tujuan penggunaan.
- ▶ **Jangan gunakan perkakas listrik dengan switch yang tidak dapat dioperasikan.** Perkakas listrik yang switchnya yang tidak berfungsi dapat menimbulkan bahaya dan harus diperbaiki.
- ▶ **Lepaskan steker dari sumber listrik dan/atau lepas baterai, jika dapat dilepaskan dari perkakas listrik sebelum menyetel, mengganti aksesoris, atau menyimpan perkakas listrik.** Tindakan preventif akan mengurangi risiko menghidupkan perkakas listrik secara tidak disengaja.
- ▶ **Jauhkan dan simpan perkakas listrik dari jangkauan anak-anak dan jangan biarkan orang-orang yang tidak mengetahui cara menggunakan perkakas listrik, mengoperasikan perkakas listrik.** Perkakas listrik

dapat membahayakan jika digunakan oleh orang-orang yang tidak terlatih.

- ▶ **Lakukan pemeliharaan perkakas listrik dan aksesoris. Periksa komponen yang bergerak apabila tidak lurus atau terikat, kerusakan komponen, dan kondisi lain yang dapat mengganggu pengoperasian perkakas listrik. Apabila rusak, perbaiki perkakas listrik sebelum digunakan.** Kecelakaan sering terjadi karena perkakas listrik tidak dirawat dengan baik.
- ▶ **Jaga ketajaman dan kebersihan alat.** Alat pemotong dengan pisau pemotong yang tajam dan dirawat dengan baik tidak akan mudah tersangkut dan lebih mudah dikendalikan.
- ▶ **Gunakan perkakas listrik, aksesoris, dan komponen perkakas dll sesuai dengan petunjuk ini, dengan mempertimbangkan kondisi kerja dan pekerjaan yang akan dilakukan.** Penggunaan perkakas listrik untuk tujuan berbeda dari fungsinya dapat menyebabkan situasi yang berbahaya.
- ▶ **Jaga gagang dan permukaan genggam agar tetap kering, bersih, dan bebas dari minyak dan lemak.** Gagang dan permukaan genggam yang licin tidak menjamin keamanan kerja dan kontrol alat yang baik pada situasi yang tidak terduga.

Servis

- ▶ **Minta teknisi berkualifikasi untuk servis perkakas listrik dengan hanya menggunakan suku cadang yang identik.** Dengan demikian, hal ini akan memastikan keamanan perkakas listrik.

Petunjuk Keselamatan untuk Mesin Gergaji

- ▶ **Pegang perkakas listrik pada permukaan gagang isolator saat digunakan karena aksesoris pemotong dapat saja bersentuhan dengan kabel yang tidak terlihat atau kabelnya sendiri.** Aksesoris pemotong yang bersentuhan dengan kabel yang dialiri listrik dapat menyebabkan bagian logam perkakas listrik yang terbuka dialiri listrik sehingga berisiko mengakibatkan sengatan listrik pada operator.
- ▶ **Gunakan penjepit atau cara lain yang praktis untuk mengamankan dan menopang benda kerja pada permukaan yang stabil.** Benda kerja dapat goyah atau kehilangan kendali jika dipegang dengan tangan atau ditahan dengan tubuh Anda.
- ▶ **Jauhkan tangan Anda dari area penggergajian. Jangan menjangkau ke bawah benda kerja.** Bersentuhan dengan mata gergaji dapat mengakibatkan cedera.
- ▶ **Hidupkan terlebih dahulu perkakas listrik, kemudian perkakas listrik didekatkan pada benda kerja.** Jika tidak, terdapat bahaya sentakan jika alat kerja tersangkut dalam benda yang dikerjakan.
- ▶ **Pastikan pelat kaki terletak dengan aman selama penggergajian.** Mata gergaji yang tersangkut dapat patah atau mengakibatkan terjadinya sentakan.

- ▶ **Matikan perkakas listrik setelah pekerjaan menggergaji selesai dan tunggu hingga mata gergaji berhenti bergerak, kemudian keluarkan mata gergaji dari jalur pemotongan.** Dengan demikian, sentakan dapat dihindari dan perkakas listrik dapat diletakkan dengan aman.
- ▶ **Sebelum meletakkan perkakas listrik, tunggulah hingga perkakas berhenti berputar.** Alat kerja dapat tersangkut dan menyebabkan perkakas listrik tidak dapat dikendalikan.
- ▶ **Gunakanlah hanya mata gergaji yang tidak rusak dan mulus.** Mata gergaji yang melengkung atau tidak tajam dapat patah, membuat potongan tidak bagus, atau mengakibatkan sentakan.
- ▶ **Setelah perkakas listrik dimatikan, jangan melakukan pengereman dengan cara menekan mata gergaji pada sisinya.** Hal tersebut dapat mengakibatkan mata gergaji menjadi rusak, patah, atau mengakibatkan sentakan.
- ▶ **Gunakanlah alat detektor logam yang cocok untuk mencari kabel dan pipa yang tidak terlihat atau hubungi perusahaan pengadaan setempat.** Sentuhan dengan kabel-kabel listrik dapat mengakibatkan api dan kontak listrik. Pipa gas yang rusak dapat mengakibatkan ledakan. Pipa air yang rusak mengakibatkan kerusakan barang-barang atau dapat mengakibatkan kontak listrik.

Spesifikasi produk dan performa



Bacalah semua petunjuk keselamatan dan petunjuk penggunaan. Kesalahan dalam menjalankan petunjuk keselamatan dan petunjuk penggunaan dapat mengakibatkan kontak listrik, kebakaran, dan/atau luka-luka yang berat.

Perhatikan ilustrasi yang terdapat pada sisi sampul panduan pengoperasian.

Tujuan penggunaan

Perkakas listrik ini cocok untuk pemotongan kayu, bahan sintetis, logam, pelat keramik dan karet. Perkakas listrik ini cocok untuk pemotongan lurus dan berliku-liku. Perhatikan petunjuk untuk penggunaan mata gergaji.

Ilustrasi komponen

Nomor-nomor dari bagian-bagian perkakas pada gambar sesuai dengan gambar perkakas listrik pada halaman bergambar.

- (1) Tutup putar SDS pembuka kunci mata gergaji
- (2) Pengunci tombol on/off
- (3) Tombol on/off
- (4) Selektor penyetelan awal kecepatan pemotongan
- (5) Pelat dasar
- (6) Switch untuk alat blower serbuk gergaji
- (7) Tuas pengatur osilasi

- (8) Dudukan mata gergaji
- (9) Rol pemandu
- (10) Pisau gergaji^{A)}
- (11) Kap pelindung debu
- (12) Pemandu mistar sejajar
- (13) Pelindung dari sentuhan tangan atau jari
- (14) Gagang (permukaan genggam berisolator)
- (15) Pelindung serpihan^{A)}
- (16) Baut pengunci mistar sejajar^{A)}
- (17) Mistar sejajar dengan pemotong bundar^{A)}
- (18) Titik pusat pemotong bundar^{A)}

A) Aksesoris yang ada pada gambar atau yang dijelaskan tidak termasuk dalam lingkup pengiriman standar. Semua aksesoris yang ada dapat Anda lihat dalam program aksesoris kami.

Data teknis

Mesin jigsaw		GST 25 M
Nomor seri		3 601 E16 ...
Kontrol kecepatan pemotongan		●
Elektronika penetap putaran		●
Input daya nominal	W	670
Kecepatan pemotongan tanpa beban n_0	min ⁻¹	500–2600
Pemotongan	mm	24
Kedalaman pemotongan maks.		
– pada kayu	mm	80
– pada aluminium	mm	25
– pada baja (non-alloy)	mm	15
Berat sesuai dengan EPTA-Procedure 01:2014	kg	2,7
Klasifikasi keamanan		□/II

Data-data berlaku untuk tegangan nominal [U] 230 V. Pada tegangan yang lebih rendah dan pada model khusus mancanegara data-data ini bisa berlainan.

Cara memasang

- **Sebelum mulai dengan pekerjaan pada perkakas listrik, tariklah steker dari stopkontak.**

Memasang/mengganti pisau gergaji

- **Pakailah sarung tangan pelindung saat memasang atau mengganti alat sisipan.** Alat sisipan sangat tajam dan dapat memanas jika digunakan dalam waktu yang lama.

Memilih pisau gergaji

Lihat ikhtisar pisau gergaji yang disarankan di akhir petunjuk ini. Hanya pasang pisau gergaji dengan pisau gergaji (berbentuk T). Pisau gergaji sebaiknya tidak lebih panjang

daripada yang diperlukan untuk pemotongan yang hendak dikerjakan.

Untuk menggergaji lekukan, gunakanlah pisau gergaji yang tidak lebar.

Memasang/melepas mata gergaji (lihat gambar A)

- **Bersihkan batang mata gergaji sebelum dipasang.**

Batang yang kotor tidak dapat dipasang dengan aman.

- ❶ Tarik tutup putar SDS (1) ke atas.
- ❷ Untuk membuka kunci, putar tutup putar SDS (1) sekitar 3 putaran berlawanan arah jarum jam.
- ❸ Pasang mata gergaji (10) menyilang ke arah pemotongan ke dalam dudukan mata gergaji (8).
- ❹ Putar mata gergaji (10) sehingga gerigi menghadap ke arah pemotongan. Pastikan punggung mata gergaji terletak di alur rol pemandu (9).
- ❺ Putar tutup putar (1) searah jarum jam hingga tutup putar terpasang dengan benar.
- ❻ Putar kembali tutup putar SDS (1) searah jarum jam hingga tutup putar berada di posisi awal. Geser tutup putar SDS ke bawah untuk mengunci tutup putar.

- **Pastikan pisau gergaji terpasang kencang.** Pisau gergaji yang tidak kencang dapat terlepas dan mencederai Anda.

Untuk melepaskan pisau gergaji, lakukan langkah di atas dalam urutan sebaliknya.

Pelindung serpihan (lihat gambar B)

Pelindung serpihan (15) (aksesori) dapat melindungi permukaan agar tidak robek saat menggergaji pada kayu. Pelindung serpihan hanya dapat digunakan pada jenis mata gergaji tertentu.

Tekan pelindung serpihan (15) dari bawah ke dalam pelat dasar (5).

Pengisapan debu/serbuk

Debu dari bahan-bahan seperti cat yang mengandung timbel (timah hitam), beberapa jenis kayu, bahan mineral dan logam dapat berbahaya bagi kesehatan. Menyentuh atau menghirup debu-debu ini dapat mengakibatkan reaksi alergi dan/atau penyakit saluran pernapasan pada pengguna atau orang yang berada di dekatnya.

Beberapa debu tertentu seperti debu kayu pohon quercus atau pohon fagus silvatica dianggap dapat mengakibatkan penyakit kanker, terutama dalam campuran dengan bahan-bahan tambahan untuk pengolahan kayu (kromat, obat pengawet kayu). Bahan-bahan yang mengandung asbes hanya boleh dikerjakan oleh orang-orang yang ahli.

- Perhatikanlah supaya ada pertukaran udara yang baik di tempat kerja.
- Kami anjurkan Anda memakai masker anti debu dengan filter kelas P2.

Taatilah peraturan-peraturan untuk bahan-bahan yang dikerjakan yang berlaku di negara Anda.

► **Hindari debu yang banyak terkumpul di tempat kerja.**

Debu dapat tersulut dengan mudah.

Kap pelindung debu (lihat gambar C)

Terdapat risiko cedera akibat serbuk gergaji logam yang tajam dan panas. Oleh karena itu, pasang kap pelindung debu **(11)** untuk pengerjaan pada logam atau aluminium.

Pasang kap pelindung debu **(11)** pada perkakas listrik sehingga penopang terkunci pada pelindung dari sentuhan tangan atau jari **(13)**.

Lepaskan kap pelindung debu **(11)** untuk pengerjaan pada kayu. Untuk itu, tarik kap pelindung debu dari pelindung sentuhan tangan atau jari **(13)** ke depan.

Penggunaan

Mode pengoperasian

► **Sebelum mulai dengan pekerjaan pada perkakas listrik, tariklah steker dari stopkontak.**

Osilasi

Osilasi memungkinkan penyesuaian kecepatan pemotongan, daya pemotongan dan hasil pemotongan yang optimal pada material kerja.

Nyalakan osilasi misalnya untuk menggergaji material lunak dan menggergaji pada kayu mengikuti arah serat kayu. Untuk itu, geser tuas pengatur **(7)** ke posisi "I". Hal tersebut juga dapat dilakukan selama pengoperasian.

Matikan osilasi untuk pemotongan tepi yang halus dan bersih serta pengerjaan pada material tipis (misalnya pelat logam). Untuk itu, geser tuas pengatur **(7)** ke posisi "0".

Alat blower serbuk gergaji

Garis potong serbuk dapat terjaga dari kotoran dengan aliran udara dari alat peniup serbuk.

Aktifkan alat blower serbuk gergaji untuk pemotongan dengan pengikisan serbuk yang berat pada kayu, bahan sintetis, dsb. Untuk itu, geser switch **(6)** ke posisi "I".

Nonaktifkan alat blower serbuk gergaji untuk pengerjaan pada logam. Untuk itu, geser switch **(6)** ke posisi "0".

Cara penggunaan

► **Perhatikan tegangan listrik! Tegangan jaringan listrik harus sesuai dengan tegangan listrik yang tercantum pada label tipe perkakas listrik. Perkakas listrik dengan daya sebesar 230 V seperti yang diindikasikan pada label dapat juga dioperasikan pada daya 220 V.**

Menghidupkan/mematikan perkakas listrik

► **Pastikan bahwa Anda dapat mengoperasikan tombol untuk menghidupkan dan mematikan tanpa perlu melepaskan handle.**

Untuk **menghidupkan** perkakas listrik, tekan tombol on/off **(3)**.

Untuk **mengunci** tombol on/off **(3)** tekan dan tahan tombol on/off dan geser tombol kunci **(2)** ke kanan atau kiri.

Untuk **mematikan** perkakas listrik, lepaskan tombol on/off **(3)**. Jika tombol on/off **(3)** terkunci, tekan terlebih dahulu tombol tersebut, kemudian lepaskan.

Elektronika penapat putaran

Elektronika penapat putaran membuat kecepatan pemotongan tanpa beban dan sewaktu dibebani hampir konstan dan menjamin daya kerja yang rata.

Mengontrol/melakukan penyetelan awal pada kecepatan pemotongan

Jumlah langkah perkakas listrik yang dihidupkan dapat disetel terus-menerus tergantung seberapa kuat tombol on/off **(3)** ditekan.

Jika tombol on/off **(3)** ditekan ringan, jumlah langkah menjadi rendah. Jika tekanan ditambah, jumlah langkah akan meningkat.

Saat tombol on/off **(3)** terkunci, jumlah langkah tidak dapat dikurangi.

Dengan roda pemilih kecepatan **(4)**, jumlah langkah dapat disetel sebelumnya dan diubah selama pengoperasian.

Jumlah langkah yang diperlukan tergantung pada material kerja dan kondisi kerja serta dapat ditentukan dengan uji coba.

Disarankan untuk mengurangi jumlah langkah saat menggunakan pisau gergaji pada benda kerja serta saat memotong bahan sintetis dan aluminium.

Jika digunakan untuk waktu yang lama dengan jumlah langkah yang rendah, perkakas listrik dapat menjadi sangat panas. Lepaskan pisau gergaji dan biarkan perkakas listrik beroperasi dengan jumlah langkah maksimal selama kira-kira 3 menit untuk didinginkan.

Petunjuk pengoperasian

► **Sebelum mulai dengan pekerjaan pada perkakas listrik, tariklah steker dari stopkontak.**

► **Segera matikan perkakas listrik jika pisau gergaji terhenti.**

► **Selalu gunakan permukaan yang stabil saat pengerjaan pada material yang kecil atau tipis.**

Sebelum melakukan pemotongan, periksa benda kerja dari benda asing seperti paku, baut atau sejenisnya pada kayu, papan partikel, material bangunan dan lainnya serta singkirkan benda asing tersebut.

Pemotongan dalam (lihat gambar D)

► **Hanya material lunak seperti kayu lunak, gipsium atau sejenisnya yang boleh digunakan pada proses pemotongan ke dalam!**

Untuk pemotongan ke dalam, hanya gunakan pisau gergaji yang pendek.

Letakkan perkakas listrik dengan tepi depan pelat dasar **(5)** pada benda kerja tanpa menyentuh mata gergaji **(10)** pada benda kerja tersebut dan nyalakan perkakas listrik.

Pada perkakas listrik dengan kontrol kecepatan pemotongan, pilih kecepatan pemotongan maksimal. Tekan kuat perkakas listrik pada benda kerja dan biarkan mata gergaji masuk perlahan.

Begitu pelat dasar (5) terletak sepenuhnya pada benda kerja, potong benda kerja sepanjang garis yang diinginkan.

Mistar sejajar dengan pemotong bundar (aksesori)

Untuk bekerja dengan mistar sejajar dan pemotong bundar (17) (aksesori) ketebalan benda kerja tidak boleh melebihi 30 mm.

Pemotongan sejajar (lihat gambar E): Kendorkan baut pengunci (16) dan geser skala mistar sejajar melalui pemandu (12) pada pelat dasar. Atur lebar potongan sebagai nilai skala pada bagian dalam pelat dasar. Kencangkan baut pengunci (16).

Pemotongan bundar (lihat gambar F): Buat lubang pada garis pemotongan di dalam lingkaran yang akan dipotong yang cukup untuk memasukkan pisau gergaji. Buat lubang dengan mesin potong atau alat kikir agar pisau gergaji dapat terletak secara merata pada garis potongan.

Pasang baut pengunci (16) ke sisi lain pada mistar sejajar. Geser skala mistar sejajar melalui pemandu (12) pada pelat dasar. Buat lubang pada benda kerja di tengah potongan yang akan digergaji. Masukkan titik pusat (18) melalui lubang bagian dalam mistar sejajar dan lubang yang dibor. Atur jari-jari sebagai nilai skala pada tepi dalam pelat dasar. Kencangkan baut pengunci (16).

Zat pendingin/pelumas

Saat menggergaji logam, gunakan zat pendingin/pelumas di sepanjang garis pemotongan akibat pemanasan pada material.

Perawatan dan servis

Perawatan dan pembersihan

- ▶ **Sebelum mulai dengan pekerjaan pada perkakas listrik, tariklah steker dari stopkontak.**
- ▶ **Perkakas listrik dan lubang ventilasi harus selalu dibersihkan agar perkakas dapat digunakan dengan baik dan aman.**

Jika kabel listrik harus diganti, pekerjaan ini harus dilakukan oleh **Bosch** atau Service Center untuk perkakas listrik **Bosch** resmi agar keselamatan kerja selalu terjamin.

Bersihkan dudukan pisau gergaji secara berkala. Untuk melakukannya, lepas pisau gergaji dari perkakas listrik dan ketukkan perkakas listrik dengan perlahan pada permukaan yang datar.

Perkakas listrik yang sangat kotor dapat tidak berfungsi dengan baik. Oleh karena itu, jangan menggergaji material yang menghasilkan banyak debu dari bawah atau di atas kepala.

- ▶ **Bila memungkinkan, selalu gunakan sistem ekstraksi udara dalam kondisi pengoperasian yang ekstrem. Tiuplah dengan rutin lubang ventilasi dan hiduapkan pemutus arus (PRCD).** Saat pengerjaan bahan logam, debu konduktif dapat mengendap di dalam perkakas listrik. Isolasi keamanan dari perkakas listrik dapat terganggu.

Oleskan rol pemandu (9) sesekali dengan setetes minyak.

Periksa rol pemandu (9) secara teratur. Jika rol pemandu aus, rol pemandu harus diganti oleh Service Center **Bosch** resmi.

Layanan pelanggan dan konsultasi penggunaan

Layanan pelanggan Bosch menjawab semua pertanyaan Anda tentang reparasi dan perawatan serta tentang suku cadang produk ini. Gambaran teknis (exploded view) dan informasi mengenai suku cadang dapat ditemukan di:

www.bosch-pt.com

Tim konsultasi penggunaan Bosch akan membantu Anda menjawab pertanyaan seputar produk kami beserta aksesorinya.

Jika Anda hendak menanyakan sesuatu atau memesan suku cadang, selalu sebutkan nomor model yang terdiri dari 10 angka dan tercantum pada label tipe produk.

Indonesia

PT Robert Bosch
Palma Tower 10th Floor
Jalan RA Kartini II-S Kaveling 6
Pondok Pinang, Kebayoran Lama
Jakarta Selatan 12310
Tel.: (021) 3005 5800
Fax: (021) 3005 5801
E-Mail: boschpowertools@id.bosch.com
www.bosch-pt.co.id

Cara membuang

Perkakas listrik, aksesoris, dan kemasan sebaiknya didaur ulang secara ramah lingkungan.



Jangan membuang perkakas listrik ke dalam sampah rumah tangga!

Tiếng Việt

Hướng dẫn an toàn

Hướng dẫn an toàn chung cho dụng cụ điện

⚠ CẢNH BÁO **Hãy đọc toàn bộ các cảnh báo an toàn, hướng dẫn, hình ảnh và thông số kỹ thuật được cung cấp cho dụng cụ điện cầm tay này.** Không tuân thủ mọi hướng dẫn được liệt kê dưới đây có thể bị điện giật, gây cháy và/hay bị thương tật nghiêm trọng. **Hãy giữ tất cả tài liệu về cảnh báo và hướng dẫn để tham khảo về sau.**

Thuật ngữ "dụng cụ điện cầm tay" trong phần cảnh báo là đề cập đến sự sử dụng dụng cụ điện cầm tay của bạn, loại sử dụng điện nguồn (có dây cắm điện) hay vận hành bằng pin (không dây cắm điện).

Khu vực làm việc an toàn

- ▶ **Giữ nơi làm việc sạch và đủ ánh sáng.** Nơi làm việc bừa bộn và tối tăm dễ gây ra tai nạn.
- ▶ **Không vận hành dụng cụ điện cầm tay trong môi trường dễ gây nổ, chẳng hạn như nơi có chất lỏng dễ cháy, khí đốt hay rác.** Dụng cụ điện cầm tay tạo ra các tia lửa nên có thể làm rác bén cháy hay bốc khói.
- ▶ **Không để trẻ em hay người đến xem đứng gần khi vận hành dụng cụ điện cầm tay.** Sự phân tâm có thể gây ra sự mất điều khiển.

An toàn về điện

- ▶ **Phích cắm của dụng cụ điện cầm tay phải thích hợp với ổ cắm.** Không bao giờ được cải biến lại phích cắm dưới mọi hình thức. Không được sử dụng phích tiếp hợp nối tiếp đất (dây mát). Phích cắm nguyên bản và ổ cắm đúng loại sẽ làm giảm nguy cơ bị điện giật.
- ▶ **Tránh không để thân thể tiếp xúc với đất hay các vật có bề mặt tiếp đất như đường ống, lò sưởi, hàng rào và tủ lạnh.** Có nhiều nguy cơ bị điện giật hơn nếu cơ thể bạn bị tiếp hay nối đất.
- ▶ **Không được để dụng cụ điện cầm tay ngoài mưa hay ở tình trạng ẩm ướt.** Nước vào máy sẽ làm tăng nguy cơ bị điện giật.
- ▶ **Không được làm dụng dây dẫn điện.** Không bao giờ được nắm dây dẫn để xách, kéo hay rút phích cắm dụng cụ điện cầm tay. Không để dây gần nơi có nhiệt độ cao, dầu nhớt, vật nhọn bén và bộ phận chuyển động. Làm hỏng hay cuộn rối dây dẫn làm tăng nguy cơ bị điện giật.
- ▶ **Khi sử dụng dụng cụ điện cầm tay ngoài trời, dùng dây nối thích hợp cho việc sử dụng ngoài trời.** Sử dụng dây nối thích hợp cho việc sử dụng ngoài trời làm giảm nguy cơ bị điện giật.
- ▶ **Nếu việc sử dụng dụng cụ điện cầm tay ở nơi ẩm ướt là không thể tránh được, dùng thiết bị ngắt mạch tự động (RCD) bảo vệ nguồn.** Sử dụng thiết bị ngắt mạch tự động RCD làm giảm nguy cơ bị điện giật.

An toàn cá nhân

- ▶ **Hãy tỉnh táo, biết rõ mình đang làm gì và hãy sử dụng ý thức khi vận hành dụng cụ điện cầm tay.** Không sử dụng dụng cụ điện cầm tay khi đang mệt mỏi hay đang bị tác động do chất gây nghiện, rượu hay được phẩm gây ra. Một thoáng mất tập trung khi đang vận hành dụng cụ điện cầm tay có thể gây thương tích nghiêm trọng cho bản thân.
- ▶ **Sử dụng trang bị bảo hộ cá nhân.** Luôn luôn đeo kính bảo vệ mắt. Trang bị bảo hộ như khẩu trang, giày chống trượt, nón bảo hộ, hay dụng cụ bảo vệ tai khi được sử dụng đúng nơi đúng chỗ sẽ làm giảm nguy cơ thương tật cho bản thân.

- ▶ **Phòng tránh máy khởi động bất ngờ.** Bảo đảm công tắc máy ở vị trí tắt trước khi cắm vào nguồn điện và/hay lắp pin vào, khi nhắc máy lên hay khi mang xách máy. Ngáng ngón tay vào công tắc máy để xách hay kích hoạt dụng cụ điện cầm tay khi công tắc ở vị trí mở dễ dẫn đến tai nạn.
- ▶ **Lấy mọi chìa hay khóa điều chỉnh ra trước khi mở điện dụng cụ điện cầm tay.** Khóa hay chìa còn gắn dính vào bộ phận quay của dụng cụ điện cầm tay có thể gây thương tích cho bản thân.
- ▶ **Không rướn người.** Luôn luôn giữ tư thế đứng thích hợp và thăng bằng. Điều này tạo cho việc điều khiển dụng cụ điện cầm tay tốt hơn trong mọi tình huống bất ngờ.
- ▶ **Trang phục thích hợp.** Không mặc quần áo rộng lủng thùng hay mang trang sức. Giữ tóc và quần áo xa khỏi các bộ phận chuyển động. Quần áo rộng lủng thùng, đồ trang sức hay tóc dài có thể bị cuốn vào các bộ phận chuyển động.
- ▶ **Nếu có các thiết bị đi kèm để nối máy hút bụi và các phụ kiện khác, bảo đảm các thiết bị này được nối và sử dụng tốt.** Việc sử dụng các thiết bị gom hút bụi có thể làm giảm các độc hại liên quan đến bụi gây ra.
- ▶ **Không để thói quen do sử dụng thường xuyên dụng cụ khiến bạn trở nên chủ quan và bỏ qua các quy định an toàn dụng cụ.** Một hành vi bất cẩn có thể gây ra thương tích nghiêm trọng chỉ trong tích tắc.

Sử dụng và bảo dưỡng dụng cụ điện cầm tay

- ▶ **Không được ép máy.** Sử dụng dụng cụ điện cầm tay đúng loại theo đúng ứng dụng của bạn. Dụng cụ điện cầm tay đúng chức năng sẽ làm việc tốt và an toàn hơn theo đúng tiến độ mà máy được thiết kế.
- ▶ **Không sử dụng dụng cụ điện cầm tay nếu như công tắc không tắt và mở được.** Bất kỳ dụng cụ điện cầm tay nào mà không thể điều khiển được bằng công tắc là nguy hiểm và phải được sửa chữa.
- ▶ **Rút phích cắm ra khỏi nguồn điện và/hay pin ra khỏi dụng cụ điện cầm tay nếu có thể tháo được, trước khi tiến hành bất kỳ điều chỉnh nào, thay phụ kiện, hay cất dụng cụ điện cầm tay.** Các biện pháp ngăn ngừa như vậy làm giảm nguy cơ dụng cụ điện cầm tay khởi động bất ngờ.
- ▶ **Cất giữ dụng cụ điện cầm tay không dùng tới nơi trẻ em không lấy được và không cho người chưa từng biết dụng cụ điện cầm tay hay các hướng dẫn này sử dụng dụng cụ điện cầm tay.** Dụng cụ điện cầm tay nguy hiểm khi ở trong tay người chưa được chỉ cách sử dụng.

- ▶ **Bảo quản dụng cụ điện cầm tay và các phụ kiện.** Kiểm tra xem các bộ phận chuyển động có bị sai lệch hay kẹt, các bộ phận bị rạn nứt và các tình trạng khác có thể ảnh hưởng đến sự vận hành của máy. Nếu bị hư hỏng, phải sửa chữa máy trước khi sử dụng. Nhiều tai nạn xảy ra do bảo quản dụng cụ điện cầm tay tồi.
- ▶ **Giữ các dụng cụ cất bện và sạch.** Bảo quản đúng cách các dụng cụ cất có cạnh cất bện làm giảm khả năng bị kẹt và dễ điều khiển hơn.
- ▶ **Sử dụng dụng cụ điện cầm tay, phụ kiện, đầu cài v. v., đúng theo các chỉ dẫn này, hãy lưu ý đến điều kiện làm việc và công việc phải thực hiện.** Sự sử dụng dụng cụ điện cầm tay khác với mục đích thiết kế có thể tạo nên tình huống nguy hiểm.
- ▶ **Giữ tay cầm và bề mặt nắm luôn khô ráo, sạch sẽ và không dính dầu mỡ.** Tay cầm và bề mặt nắm trơn trượt không đem lại thao tác an toàn và kiểm soát dụng cụ trong các tình huống bất ngờ.

Bảo dưỡng

- ▶ **Đưa dụng cụ điện cầm tay của bạn đến thợ chuyên môn để bảo dưỡng, chỉ sử dụng phụ tùng đúng chủng loại để thay.** Điều này sẽ đảm bảo sự an toàn của máy được giữ nguyên.

Hướng dẫn an toàn cho loại Máy Cưa Xoi

- ▶ **Chỉ cắm dụng cụ điện tại các bề mặt cầm nắm có cách điện, khi thực hiện một thao tác tại vị trí mà phụ kiện cắt có thể tiếp xúc với dây điện ngầm hoặc chính dây điện của thiết bị.** Phụ kiện cắt tiếp xúc với dây có điện có thể làm cho các phần kim loại hở của dụng cụ điện cầm tay có điện và có thể gây ra điện giật cho người vận hành.
- ▶ **Sử dụng các kẹp hoặc cách thực tiễn khác để cố định và đỡ phôi gia công vào sàn thao tác cố định.** Việc cầm phôi gia công bằng tay hoặc tựa người vào phôi gia công làm cho nó dễ đổ và có thể dẫn đến mất kiểm soát.
- ▶ **Để tay tránh xa khỏi phạm vi cắt. Không được tiếp chạm với phần bên dưới vật gia công.** Tiếp xúc với lưỡi cưa có thể dẫn đến việc bị thương tích.
- ▶ **Chỉ cho máy gia công vật liệu khi máy đã hoạt động.** Nếu không làm vậy thì sẽ có nguy cơ bị giật ngược do dụng cụ cắt bị kẹt chặt trong vật gia công.
- ▶ **Đảm bảo rằng, để đĩa đã nằm an toàn trên vật liệu trong khi cưa.** Lưỡi cưa bị kẹt chặt có thể bị gãy hay gây ra sự giật ngược.
- ▶ **Khi đã cắt xong, tắt máy và sau đó rút lưỡi cưa ra khỏi mạch cắt chỉ sau khi lưỡi cưa đã ngừng chuyển động hoàn toàn.** Thực hiện như

vậy bạn có thể tránh được sự giật ngược và có thể đặt máy xuống một cách an toàn.

- ▶ **Luôn luôn đợi cho máy hoàn toàn ngừng hẳn trước khi đặt xuống.** Dụng cụ lắp vào máy có thể bị kẹt chặt dẫn đến việc dụng cụ điện cầm tay bị mất điều khiển.
- ▶ **Chỉ sử dụng lưỡi cưa còn nguyên vẹn, có tình trạng hoàn hảo.** Lưỡi cưa bị cong hay cùn có thể bị gãy, ảnh hưởng xấu đến sự cắt, và có thể gây ra sự dội ngược.
- ▶ **Không được hãm lưỡi cưa cho dừng lại bằng cách tạo lực ép lên hông lưỡi cưa sau khi tắt máy.** Lưỡi cưa có thể bị hỏng, gãy hay gây ra giật ngược.
- ▶ **Dùng thiết bị dò tìm thích hợp để xác định nếu có các công trình công cộng lắp đặt ngầm trong khu vực làm việc hay liên hệ với Cty công trình công cộng địa phương để nhờ hỗ trợ.** Đụng chạm đường dẫn điện có thể gây ra hỏa hoạn và điện giật. Làm hư hại đường dẫn khí ga có thể gây nổ. Làm thủng đường dẫn nước gây hư hỏng tài sản hay có khả năng gây ra điện giật.

Mô Tả Sản Phẩm và Đặc Tính Kỹ Thuật



Đọc kỹ mọi cảnh báo an toàn và mọi hướng dẫn. Không tuân thủ mọi cảnh báo và hướng dẫn được liệt kê dưới đây có thể bị điện giật, gây cháy và / hay bị thương tật nghiêm trọng.

Xin lưu ý các hình minh hoạt trong phần trước của hướng dẫn vận hành.

Sử dụng đúng cách

Máy được thiết kế để cắt đứt và cắt loại bỏ gỗ, nhựa mù, kim loại, gốm tấm và cao su khi các vật liệu này nằm bám chắc trên vật gia công. Máy cũng thích hợp để cắt các đường thẳng và cong. Nên tuân thủ các khuyến nghị loại lưỡi cưa nên sử dụng.

Các bộ phận được minh họa

Sự đánh số các biểu trưng của sản phẩm là để tham khảo hình minh họa của máy trên trang hình ảnh.

- (1) Nắp xoay SDS mở khóa lưỡi cưa
- (2) Nút khóa tự chạy của công tắc Tắt/Mở
- (3) Công tắc bật/tắt
- (4) Núm xoay chọn trước tần suất nhíp chạy
- (5) Đế đĩa
- (6) Công tắc thiết bị thổi mát cưa
- (7) Gạt chỉnh đặt động tác xoay
- (8) Bộ phận gắn lưỡi cưa

- (9) Bánh lăn định hướng
- (10) Giấy nhám^{A)}
- (11) Nắp che bụi
- (12) Cờ chỉnh đặt của đường cặp cạnh
- (13) Thanh bảo vệ chống tiếp xúc
- (14) Tay nắm (bề mặt nắm cách điện)
- (15) Miếng chặn chống tưa^{A)}
- (16) Vít xiết của đường cặp cạnh^{A)}
- (17) Đường cặp cạnh có dao cắt lỗ tròn^{A)}
- (18) Đầu định tâm của dao cắt lỗ tròn^{A)}

A) Phụ tùng được trình bày hay mô tả không phải là một phần của tiêu chuẩn hàng hóa được giao kèm theo sản phẩm. Bạn có thể tham khảo tổng thể các loại phụ tùng, phụ kiện trong chương trình phụ tùng của chúng tôi.

Thông số kỹ thuật

Cửa xoi	GST 25 M	
Mã số máy		3 601 E16 ...
Điều khiển tần suất nhịp chạy		●
Bộ phận điều áp điện tử		●
Công suất vào danh định	W	670
Tần suất nhịp chạy không tải n_0	min ⁻¹	500-2600
Nhịp chạy	mm	24
Công suất cắt tối đa		
– ở gỗ	mm	80
– ở nhôm	mm	25
– ở thép (không hợp kim)	mm	15
Trọng lượng theo Quy trình EPTA- Procedure 01:2014	kg	2,7
Cấp độ bảo vệ		□/

Các giá trị đã cho có hiệu lực cho điện thế danh định [U] 230 V. Đối với điện thế thấp hơn và các loại máy dành riêng cho một số quốc gia, các giá trị này có thể thay đổi.

Sự lắp vào

- ▶ Trước khi tiến hành bất cứ việc gì trên máy, kéo phích cắm điện nguồn ra.

Thay/Lắp Lưỡi Cửa

- ▶ Hãy mang găng tay bảo hộ khi lắp ráp hoặc thay dụng cụ. Dụng cụ có cạnh sắc và có thể nóng khi sử dụng lâu.

Chọn Lưỡi Cửa

Bạn sẽ tìm thấy một tổng quan các lưỡi cửa khuyến nghị ở cuối hướng dẫn vận hành. Chỉ sử dụng lưỡi

cửa có chuỗi gờ đơn (chuỗi chữ T). Lưỡi cửa không nên dài hơn mức cần thiết đối với dự kiến cắt.

Sử dụng lưỡi cửa bản hẹp khi cửa các đường cong gắt.

Lắp/tháo lưỡi cửa (xem hình A)

- ▶ **Vệ sinh trục của lưỡi cửa trước khi lắp.** Một trục bẩn có thể không được siết chặt.

- ❶ Bạn kéo nắp xoay (1) lên trên.
- ❷ Để mở khóa hãy xoay nắp xoay SDS (1) khoảng 3 vòng ngược chiều kim đồng hồ.
- ❸ Đặt lưỡi cửa (10) vuông góc với hướng cắt vào bộ phận gắn lưỡi cửa (8).
- ❹ Xoay lưỡi cửa (10), sao cho răng cửa chỉ theo hướng cắt. Lưu ý sao cho sống lưỡi cửa nằm trong rãnh của bánh răng định hướng (9).
- ❺ Hãy xoay nắp xoay SDS (1) theo chiều kim đồng hồ, đến khi khớp vào vị trí.
- ❻ Xoay nắp xoay SDS (1) theo chiều kim đồng hồ vào vị trí đầu ra. Hãy đẩy nắp xoay SDS xuống dưới, để khóa.

- ▶ **Kiểm tra lưỡi cửa có được bắt chắc vào.** Lưỡi cửa gắn vào còn lỏng có thể rơi ra và gây thương tích.

Để tháo lưỡi cửa, tiến hành theo qui trình ngược lại.

Miếng chặn chống tưa (xem hình B)

Miếng chặn chống tưa (15) (phụ kiện) có thể giúp tránh việc cọ sần mặt trên khi cửa gỗ. Tấm chắn mảnh vụn có thể chỉ được sử dụng với một số loại lưỡi cửa xác định.

Ấn miếng chặn chống tưa (15) từ dưới vào đế đĩa (5).

Hút Dặm/Bụi

Mặt bụi từ các vật liệu được sơn phủ ngoài có chứa chì trên một số loại gỗ, khoáng vật và kim loại có thể gây nguy hại đến sức khoẻ con người. Đụng chạm hay hít thở các bụi này có thể làm người sử dụng hay đứng gần bị dị ứng và/hoặc gây nhiễm trùng hệ hô hấp.

Một số mặt bụi cụ thể, ví dụ như bụi gỗ sồi hay dâu, được xem là chất gây ung thư, đặc biệt là có liên quan đến các chất phụ gia dùng xử lý gỗ (chất cromat, chất bảo quản gỗ). Có thể chỉ nên để thợ chuyên môn gia công các loại vật liệu có chứa amiăng.

- Tạo không khí thông thoáng nơi làm việc.
- Khuyến nghị nên mang mặt nạ phòng độc có bộ lọc cấp P2.

Tuân thủ các qui định của quốc gia bạn liên quan đến loại vật liệu gia công.

- ▶ **Tránh không để rác tích tụ tại nơi làm việc.** Rác có thể dễ dàng bắt lửa.

Nắp che bụi (xem hình C)

Nguy cơ bị thương do vỏ bào kim loại nóng và sắc. Do đó hãy lắp nắp che bụi để làm việc trên kim loại hoặc nhôm (11).

Hãy đặt nắp che bụi (11) lên dụng cụ điện, sao cho giá đỡ khớp trên thanh bảo vệ chống tiếp xúc (13). Hãy tháo nắp che bụi (11) để làm việc trên gỗ. Hãy kéo nắp che bụi về phía trước khỏi thanh bảo vệ chống tiếp xúc (13).

Vận Hành**Chế độ hoạt động**

- **Trước khi tiến hành bất cứ việc gì trên máy, kéo phích cắm điện nguồn ra.**

Động tác xoay vòng

Động tác xoay vòng cho phép điều chỉnh tối ưu tốc độ cắt cho phép, công suất cắt và hình ảnh cắt phù hợp với vật liệu cần gia công.

Hãy bật động tác xoay vòng, ví dụ để cưa các vật liệu mềm và khi cưa gỗ theo chiều sợi. Hãy đẩy cần điều chỉnh (7) vào vị trí „I“. Điều này cũng có thể thực hiện trong quá trình hoạt động.

Hãy tắt động tác xoay vòng để cho các cạnh mịn và sạch cũng như khi gia công các vật liệu mỏng (ví dụ, tấm kim loại). Hãy đẩy công tắc (7) vào vị trí „0“.

Bộ phận thổi mát cửa

Luồng gió từ thiết bị thổi mát cửa có thể giúp làm sạch mặt cửa khỏi đường cắt.

Hãy bật bộ phận thổi mát cửa để làm việc với lượng mặt cửa trên gỗ, nhựa, vv. Hãy đẩy công tắc (6) vào vị trí „I“.

Hãy tắt bộ phận thổi mát cửa để làm việc trên kim loại. Hãy đẩy công tắc (6) vào vị trí „0“.

Bắt Đầu Vận Hành

- **Hãy cẩn thận với nguồn điện! Điện thế nguồn phải đúng với điện thế đã ghi rõ trên nhãn máy. Dụng cụ điện được ghi 230 V cũng có thể được vận hành ở 220 V.**

Bật/Tắt

- **Hãy đảm bảo rằng, bạn có thể nhấn Công tắc bật/tắt, mà không cần nhả tay nắm.**

Để **bật** dụng cụ điện cầm tay, bạn hãy nhấn công tắc bật/tắt (3).

Để **khóa** công tắc bật/tắt (3), hãy bấm giữ công tắc và đẩy chốt khóa (2) sang phải hoặc trái.

Để **tắt** dụng cụ điện cầm tay hãy nhả công tắc bật/tắt (3). Khi công tắc bật/tắt bị khóa (3) hãy nhấn nó và sau đó nhả ra.

Bộ Phận Điều Áp Điện Tử

Bộ kiểm soát sự ổn định điện tử giữ cho tần suất nhịp chạy hầu như ổn định trong tình trạng có tải

cũng như không tải và đảm bảo sự đồng bộ trong hiệu suất vận hành.

Điều Khiển/Chỉnh Đặt Trước Tần Suất Nhịp Chạy

Bạn có thể điều tiết liên tục tốc độ nhịp chạy của dụng cụ điện đã bật, tùy vào việc bạn nhấn công tắc Tắt/Mở như thế nào (3).

Bấm nhẹ công tắc bật/tắt (3) sẽ cho tốc độ nhịp cửa chậm. Tăng lực bóp cũng là làm tăng tần suất nhịp chạy.

Khi công tắc bật/tắt (3) bị khóa, không thể giảm tốc độ nhịp cửa.

Với núm vặn điều chỉnh tốc độ nhịp cửa (4), bạn có thể chọn trước tốc độ này và thay đổi trong khi đang vận hành thiết bị.

Tần suất nhịp chạy cần có tốt nhất tùy thuộc vào loại vật liệu và điều kiện làm việc và có thể xác định thông qua việc chạy thử thực tế.

Khuyến nghị nên làm giảm tần suất nhịp chạy khi lưỡi cửa bắt đầu ăn vào vật liệu cũng như khi cửa nhựa mù hay nhôm.

Sau một thời gian dài vận hành với tần suất nhịp chạy thấp, máy có thể bị nóng lên đáng kể. Tháo lưỡi cửa ra khỏi máy và làm cho máy nguội xuống bằng cách cho chạy với tần suất nhịp chạy tối đa trong khoảng 3 phút.

Hướng Dẫn Sử Dụng

- **Trước khi tiến hành bất cứ việc gì trên máy, kéo phích cắm điện nguồn ra.**
- **Tắt dụng cụ điện ngay nếu lưỡi cửa bị chặn.**
- **Hãy sử dụng tấm chêm ổn định khi gia công phiôi gia công nhỏ hơn hoặc mỏng hơn.**

Kiểm tra phát hiện dị vật như kim, ốc vít các loại trước khi cưa trên gỗ thịt, gỗ ép, vật liệu xây dựng v.v. và loại bỏ chúng nếu cần.

Cắt xọc (xem hình D)

- **Chỉ được gia công các vật liệu mềm như gỗ mềm, tấm vữa trong quy trình cưa chìm!**

Để cắt xọc, chỉ sử dụng lưỡi cửa ngắn.

Hãy đặt dụng cụ chạy điện với cạnh trước của đế đĩa (5) lên chi tiết gia công mà không để lưỡi cửa (10) chạm vào chi tiết đó rồi bật dụng cụ. Đối với dụng cụ điện có bộ phận kiểm soát tốc độ nhịp chạy, chỉnh đặt ở tốc độ nhịp chạy tối đa. Khiến dẫn dụng cụ điện thật chắc tay xuống vật gia công và để cho lưỡi cửa từ từ đâm xọc vào vật gia công. Ngay khi đế đĩa (5) gần chạm vào dụng cụ, hãy cưa tiếp dọc theo đường cắt mong muốn.

Dưỡng cặp cạnh có dao cắt lỗ tròn (phụ kiện)

Để làm việc với dưỡng cặp cạnh có dao cắt lỗ tròn (17) (phụ kiện), vật liệu gia công chỉ được phép dày tối đa là 30 mm.

Cắt song song (xem hình E): Nới lỏng vít xiết (16) và đẩy thước đo dưỡng cặp cạnh bằng ray (12) trên

để đĩa. Chính đặt độ rộng muốn có giống như trị số trên thước chia độ trên biên trong của cạnh đế đĩa. Vận chặt vít xiết (16).

Cắt tròn (xem hình F): Khoan một lỗ trên đường cắt bên trong vòng tròn cần của đủ để đưa lưỡi của vào. Gia công lỗ bằng máy phay hoặc dũa để lưỡi của có thể nằm chính xác trên đường cắt.

Đặt vít xiết (16) lên mặt khác của đường cặp cạnh. Đây thước đo của đường cặp cạnh dọc ray dẫn hướng (12) vào đế đĩa. Khoan một lỗ giữa tâm vật gia công nằm trong phần bị của. Cắm đầu định tâm (18) vào lỗ trong của đường cặp cạnh và lỗ đã khoan. Chính đặt khoảng cách của bán kính giống như trị số của thước chia độ trên biên trong của cạnh đế đĩa. Vận chặt vít xiết (16).

Dung dịch làm mát/Bôi trơn

Khi của kim loại vật liệu gia công bị nóng lên, do đó; nên bôi dung dịch làm mát/bôi trơn dọc theo đường cắt.

Bảo Dưỡng và Bảo Quản

Bảo Dưỡng Và Làm Sạch

- ▶ **Trước khi tiến hành bất cứ việc gì trên máy, kéo phích cắm điện nguồn ra.**
- ▶ **Để được an toàn và máy hoạt động đúng chức năng, luôn luôn giữ máy và các khe thông gió được sạch.**

Nếu như cần phải thay dây dẫn điện thì công việc này phải do hãng **Bosch**, hay một đại lý được **Bosch** ủy nhiệm thực hiện để tránh gặp sự nguy hiểm do mất an toàn.

Làm sạch phần lắp lưỡi của thường xuyên. Để thực hiện, lấy lưỡi của trong máy ra và gõ nhẹ máy xuống chỗ có bề mặt phẳng.

Máy bị quá dơ có thể làm cho sự hoạt động bị trục trặc. Không của các vật liệu sinh nhiều bụi từ bên dưới hoặc phía trên đầu.

- ▶ **Luôn sử dụng thiết bị hút nếu có khả năng khi vận hành dụng cụ trong điều kiện khắc nghiệt. Thường xuyên thổi sạch các khe thông gió và lắp đặt thiết bị ngắt mạch tự động (PRCD).** Khi gia công kim loại, các loại hạt bụi dẫn điện có thể lọt vào trong dụng cụ điện. Toàn bộ sự cách điện của dụng cụ điện có thể bị mất tác dụng.

Thì thoáng, bôi trơn bánh lăn định hướng (9) với một giọt dầu.

Thường xuyên kiểm tra bánh lăn định hướng (9). Nếu bị mòn, phải đưa đến đại lý bảo hành-bảo trì do **Bosch** ủy nhiệm để thay.

Dịch vụ hỗ trợ khách hàng và tư vấn sử dụng

Bộ phận phục vụ hàng sau khi bán của chúng tôi trả lời các câu hỏi liên quan đến việc bảo dưỡng và

sửa chữa các sản phẩm cũng như phụ tùng thay thế của bạn. Sơ đồ mô tả và thông tin về phụ tùng thay thế cũng có thể tra cứu theo dưới đây:

www.bosch-pt.com

Đội ngũ tư vấn sử dụng của Bosch sẽ giúp bạn giải đáp các thắc mắc về sản phẩm và phụ kiện.

Trong tất cả các phản hồi và đơn đặt phụ tùng, xin vui lòng luôn luôn nhập số hàng hóa 10 chữ số theo nhãn của hàng hóa.

Việt Nam

CN CÔNG TY TNHH BOSCH VIỆT NAM TẠI TP.HCM

Tầng 14, Ngôi Nhà Đức, 33 Lê Duẩn
Phường Bến Nghé, Quận 1, Thành Phố Hồ Chí Minh

Tel.: (028) 6258 3690

Fax: (028) 6258 3692 - 6258 3694

Hotline: (028) 6250 8555

Email: tuvankhachhang-pt@vn.bosch.com

www.bosch-pt.com.vn

www.baohanhbosch-pt.com.vn

Campuchia

Công ty TNHH Robert Bosch (Campuchia)

Đơn nguyên 8BC, GT Tower, Tầng 08, Đường 169,
Tiệp Khắc Blvd, Sangkat Veal Vong,

Khan 7 Makara, Phnom Penh

VAT TIN: 100 169 511

Tel.: +855 23 900 685

Tel.: +855 23 900 660

www.bosch.com.kh

Sự thải bỏ

Máy, linh kiện và bao bì phải được phân loại để tái chế theo hướng thân thiện với môi trường.



Không được thải bỏ dụng cụ điện vào chung với rác sinh hoạt!



for wood

speed  **Wood**

T 144 D, ...

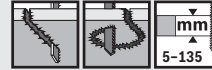

precision  **Wood**

T 308 BP, ...

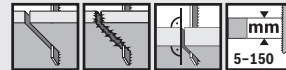

progressor  **Wood**

T 234 X, ...

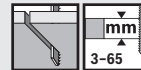

clean  **Wood**

T 101 A0, ...



extra-clean  **Wood**

T 308 B, ...

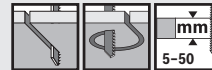



for hardwood

speed **HardWood**

T 144 DF, ...

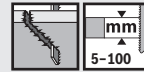

precision **HardWood**

T 308 BFP, ...

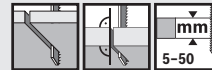

clean **HardWood**

T 101 AOF, ...

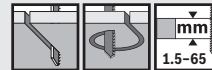

extra-clean **HardWood**

T 308 BF, ...



special **Laminate**

T 101 AOF, ...

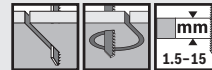

for wood and metal

progressor **Wood+Metal**

T 345 XF, ...

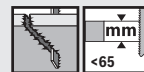



for metal

flexible  **Metal**

T 118 AF, ...

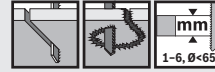

flexible  **MetalSandwich**

T 718 BF, ...

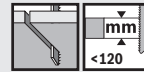

speed  **Metal**

T 121 GF, ...

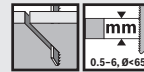

precision  **MetalSandwich** **T 1018 AFP, ...**

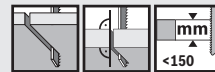

progressor  **Metal**

T 123 XF, ...

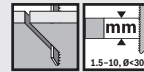

special  **Alu**

T 127 D, ...

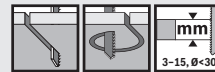

endurance  **StainlessSteel** **T 118 AHM, ...**

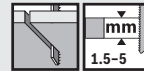



for plastics

clean **for PP**

T 102 D, ...

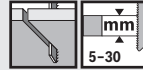

clean **for PVC**

T 102 H, ...

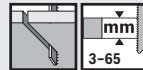

precision **for PVC**

T 1044 HP, ...

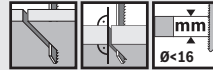

clean **for PMMA**

T 102 BF, ...

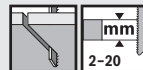

clean **for PC**

T 101 A, ...

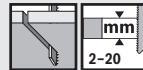

clean **for CarbonFiber** T 108 BHM, ...

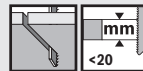

clean **for HPL**

T 128 BHM, ...

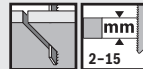

clean **for PlasticComposites** T 301 CHM, ...





for special materials

precision  **SoftMaterial T 1013 AWP, ...**

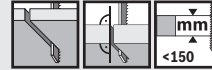

special  **SoftMaterial T 113 A, ...**

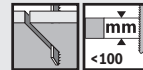

special  **Ceramic T 130 RF, ...**



endurance  **FiberPlaster T 141 HM, ...**

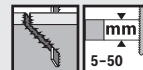

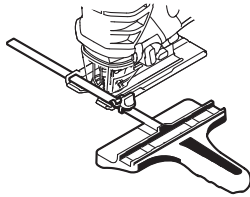

2 608 040 289



2 607 010 079 (5x)